

ISSUES:	AS-BUILTS	12-OCT-11
A	PRICING	02-DEC-11
B	PLANNING REVIEW	08-FEB-12
C	PLANNING REVIEW	10-FEB-12
D	ALTERATION PERMIT	07-MAR-12
E	ALTERATION PERMIT	22-MAR-12
F	PRICING	25-APR-12
G	BUILDING PERMIT	01-AUG-12
H	ALTERATION PERMIT	02-NOV-12
I	REVISIONS	

PROJECT INFORMATION

CIVIC ADDRESS: 4797 HIGHWAY, WEST VANCOUVER BC
LEGAL DESCRIPTION: AMENDED LOT 2 (SEE 720511) BLOCK 2 DISTRICT LOT 611 PLAN 967
APPLICABLE ZONING BYLAW: DISTRICT OF WEST VANCOUVER ZONING BYLAW (NO. 4602)
APPLICABLE DISTRICT SCHEDULE: RS3 DISTRICT SCHEDULE

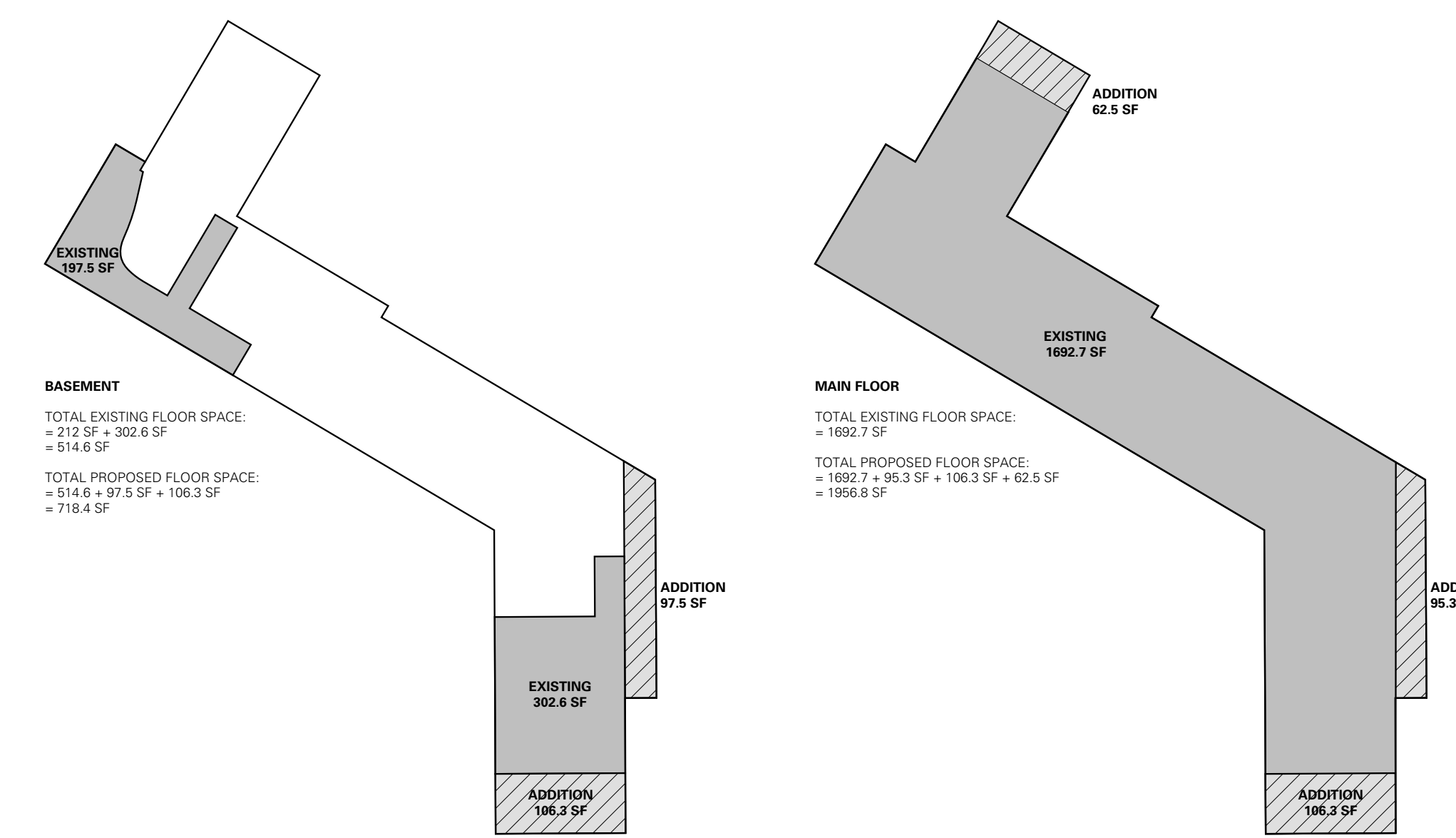

ZONING ANALYSIS

- SITE AREA**
SITE AREA = 12,549 SF (1,165.8 SM)
- FLOOR AREA RATIOS ALLOWED**
= 0.35 OF SITE AREA
= 12,549 SF X 0.35
= 4,392 SF (408 SM)
- FLOOR SPACE RATIOS**
EXISTING
BASEMENT = 500.3 SF (46.5 SM)
MAIN = 1,992 SF (187.2 SM)
TOTAL EXISTING FLOOR SPACE = 2,492.3 SF (233.7 SM)
PROPOSED
BASEMENT = 704.0 SF (65.4 SM)
MAIN = 1,958.8 SF (181.8 SM)
TOTAL PROPOSED FLOOR SPACE = 2,662.8 SF (247.2 SM)
TOTAL FLOOR SPACE ADDED
= 213%
- SITE COVERAGE ALLOWED OUTRIGHT**
= 30%
= 12,549 X 0.45
= 5,647.1 SF (524.6 SM)
- SITE COVERAGE**
EXISTING
DWELLING = 1,702.4 SF (158.2 SM)
DECKS/STAIRS ABOVE 2' = 248.7 SF (23.1 SM)
GARAGE = 214 SF (19.9 SM)
TOTAL EXISTING SITE COVERAGE = 2,165.1 SF (201.2 SM)
PROPOSED
DWELLING = 1,846.8 SF (171.6 SM)
DECKS/STAIRS ABOVE 2' = 969.3 SF (92.9 SM)
GARAGE = 214 SF (19.9 SM)
TOTAL PROPOSED SITE COVERAGE = 2,630.1 SF (244.3 SM)
- PRIMARY BUILDING SETBACKS**
FRONT YARD
ALLOWED = 29.86' (9.1 M)
EXISTING = 23.23' (7.08 M)
PROPOSED = 16.5' (5.04 M)
REAR YARD (NOTE: EXISTING NON-CONFORMITY)
ALLOWED = 29.86' (9.1 M)
EXISTING = 9.58' (2.92 M)
PROPOSED = 9.58' (2.92 M)
WEST SIDE YARD
ALLOWED = 7.87' (2.4 M)
EXISTING = 7.87' (2.4 M)
PROPOSED = 7.87' (2.4 M)
EAST SIDE YARD
ALLOWED = 9.51' (2.9 M)
EXISTING = 10.96' (3.34 M)
PROPOSED = 8.20' (2.5 M)

ZONING ANALYSIS CONT.

- BUILDING HEIGHT**
AVERAGE NATURAL GRADE = 71.7'
BUILDING HEIGHT ALLOWED = 71.7' + 25' = 96.7' (29.5 M)
EXISTING T.O. RIDGE ELEVATION = 89.4' (27.2 M)
AVERAGE FINISHED GRADE = 70.6'
BUILDING HEIGHT ALLOWED = 70.6' + 25' = 95.6' (29.1 M)
PROPOSED T.O. RIDGE ELEVATION = 89.4' (27.2 M)
AVERAGE NATURAL GRADE CALCULATION:
88.3+70.9(2)/16.2 = 1127.5
(70.9+72.0)/2+4 = 285.8
(72.0+73.9)/2+14.1 = 1028.6
(73.9+74.8)/2+12.5 = 929.4
(74.8+74.0)/2+14.1 = 1049.0
(74.0+75.5)/2+16.6 = 1539.9
(75.5+75.1)/2+15 = 113.0
(75.1+71.1)/2+3.1 = 2419.6
(71.1+68.4)/2+4 = 2528.9
(68.4+68.4)/2+15.2 = 1039.7
(68.4+74.1)/2+15.5 = 2039.6
(74.1+68.3)/2+1 = 4343.2
TOTAL: 257.2 18445.2
18445.2/257.2 = 71.7'
AVERAGE FINISHED GRADE CALCULATION:
88.3+70.9(2)/16.2 = 1131.6
(70.9+72.0)/2+4 = 285.8
(72.0+73.9)/2+14.1 = 1028.6
(73.9+74.8)/2+12.5 = 929.4
(74.8+74.0)/2+14.1 = 1049.0
(74.0+75.5)/2+16.6 = 1539.9
(75.5+75.1)/2+15 = 113.0
(75.1+71.1)/2+3.1 = 2419.6
(71.1+68.4)/2+4 = 2528.9
(68.4+68.4)/2+15.2 = 1039.7
(68.4+74.1)/2+15.5 = 2039.6
(74.1+68.3)/2+1 = 4358.5
TOTAL: 262.9 18528.7
18528.7/262.9 = 70.5'

D'ARCY JONES DESIGN INC
 204 - 175 Broadway East
 Vancouver BC V5T 1W2
 T 604 669 2235
 F 604 669 2231
 E mail@darcyjones.com

SCALE:
1/8" = 1'-0"
DATE:
25-APR-12
DRAWN:
MP
CHECKED:
DJ
REVISION:
ISSUE:
PRICING:
CONSULTANT:

Copyright reserved. All parts of this drawing are the exclusive property of D'ARCY JONES DESIGN INC and shall not be used without permission, in part or in whole.
 DO NOT SCALE THESE DRAWINGS
 All dimensions to be verified by contractor, trades or suppliers. Any discrepancies shall be brought to the attention of the Designer.
 Any errors or omissions on this drawing shall be reported to D'ARCY JONES DESIGN INC for clarification and revision.

THE OLD HIGHWAY RENOVATION
 4797 HIGHWAY
 WEST VANCOUVER BC

A0

PROPOSED SITE PLAN



PROPOSED SITE PLAN
 SCALE: 1/8" = 1'-0"

PROPOSED SIDE YARD ADDITION PROJECTION, AS PER ALTERATION PERMIT
 PROPOSED SIDE YARD OVERHANG PROJECTION, AS PER ALTERATION PERMITS

SITE BENCHMARK
 CONCRETE NAIL

ISSUES:		
A	AS-BUILTS	12-OCT-11
B	SCHEMATIC DESIGN	10-NOV-11
C	PLANNING REVIEW	07-FEB-12
D	PLANNING REVIEW	10-FEB-12
E	ALTERATION PERMIT	07-MAR-12
F	ALTERATION PERMIT	22-MAR-12
G	PRICING	25-APR-12
H	BUILDING PERMIT	01-AUG-12
I	ALTERATION PERMIT REVISIONS	01-NOV-12

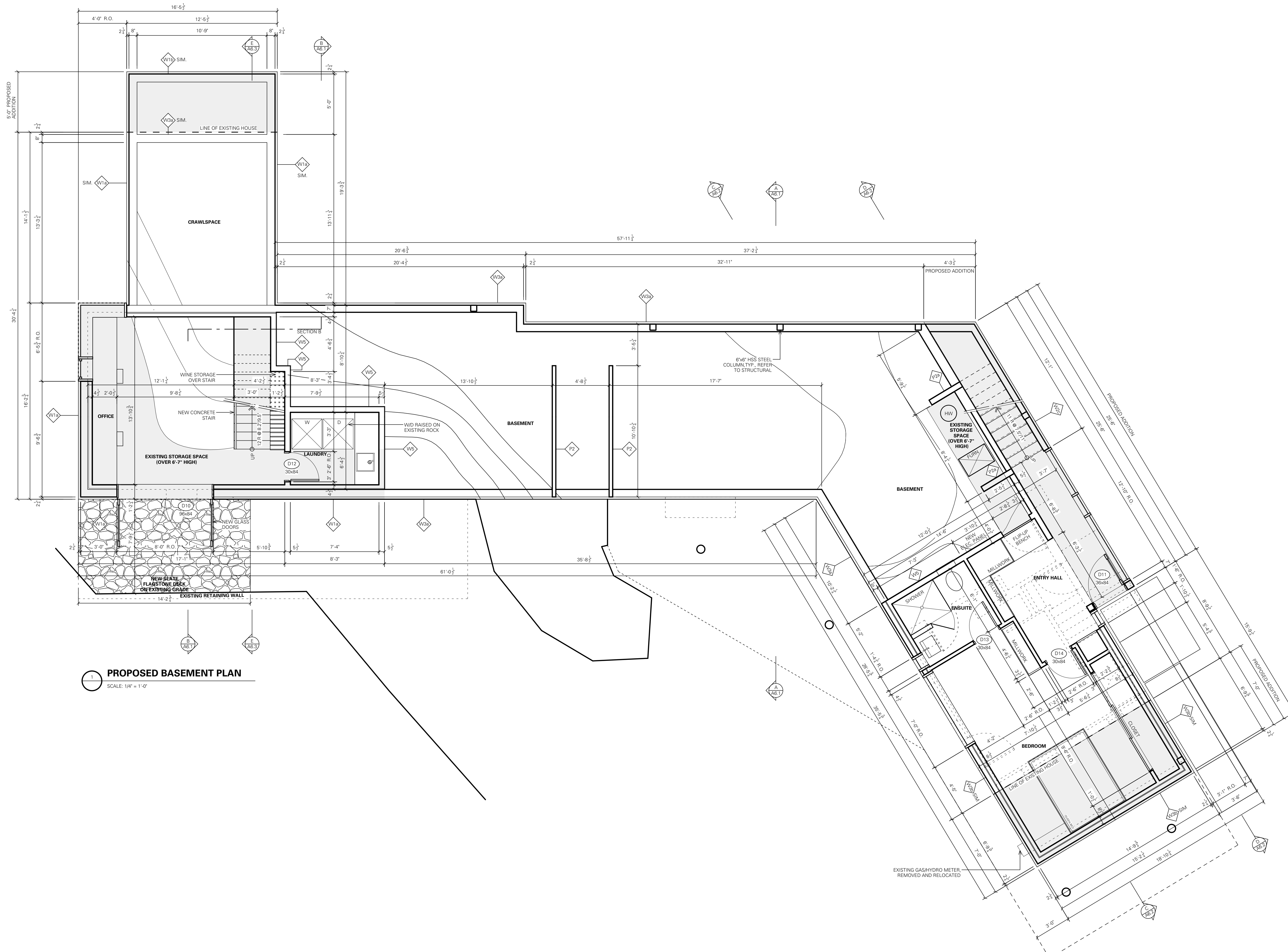

1 PROPOSED BASEMENT PLAN
SCALE: 1/4" = 1'-0"

D'ARCY JONES DESIGN INC
204 - 175 Broadway East
Vancouver BC V5T 1W2
T 604 669 2235
F 604 669 2231
E mail@darcyjones.com

SCALE:
1/4" = 1'-0"
DATE:
25-APR-12
DRAWN:
MP
CHECKED:
DJ
REVISION:
ISSUE:
PRICING
CONSULTANT:

Copyright reserved. All parts of this drawing are the exclusive property of D'ARCY JONES DESIGN INC and shall not be used without permission, in part or in whole.
DO NOT SCALE THESE DRAWINGS
All dimensions to be verified by contractor, trades or suppliers. Any discrepancies shall be brought to the attention of the Designer.
Any errors or omissions on this drawing shall be reported to D'ARCY JONES DESIGN INC for clarification and revision.

THE OLD HIGHWAY RENOVATION
4797 HIGHWAY
WEST VANCOUVER BC

A2.1b

PROPOSED BASEMENT PLAN

ISSUES:		
A	AS-BUILTS	12-OCT-11
B	SCHEMATIC DESIGN	10-NOV-11
C	PLANNING REVIEW	08-FEB-12
D	PLANNING REVIEW	10-FEB-12
E	ALTERATION PERMIT	07-MAR-12
F	ALTERATION PERMIT	22-MAR-12
G	PRICING	25-APR-12
H	BUILDING PERMIT	01-AUG-12
I	ALTERATION PERMIT REVISIONS	01-NOV-12

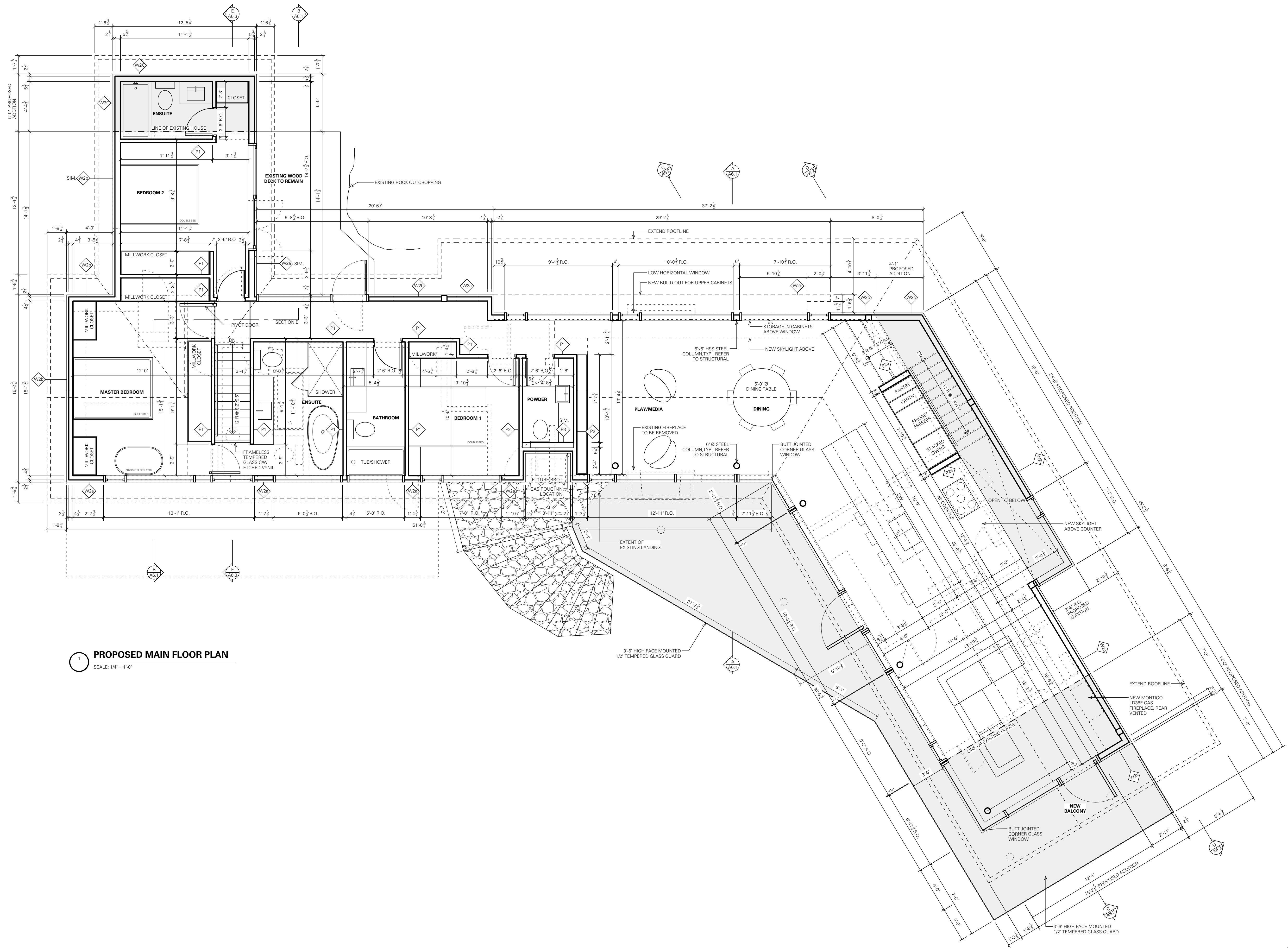

1 PROPOSED MAIN FLOOR PLAN
SCALE: 1/4" = 1'-0"

D'ARCY JONES DESIGN INC
204 - 175 Broadway East
Vancouver BC V5T 1W2
T 604 669 2235
F 604 669 2231
E mail@darcyjones.com

SCALE:
1/4" = 1'-0"
DATE:
25-APR-12
DRAWN:
MP
CHECKED:
DJ
REVISION:
ISSUE:
PRICING
CONSULTANT:

Copyright reserved. All parts of this drawing are the exclusive property of D'ARCY JONES DESIGN INC and shall not be used without permission, in part or in whole.
DO NOT SCALE THESE DRAWINGS
All dimensions to be verified by contractor, trades or suppliers. Any discrepancies shall be brought to the attention of the Designer.
Any errors or omissions on this drawing shall be reported to D'ARCY JONES DESIGN INC for clarification and revision.

THE OLD HIGHWAY RENOVATION
4797 HIGHWAY
WEST VANCOUVER BC

A3.1b

PROPOSED MAIN FLOOR PLAN

ISSUES:		
A	AS-BUILTS	12-OCT-11
B	PLANNING REVIEW	08-FEB-12
C	PLANNING REVIEW	10-FEB-12
D	ALTERATION PERMIT	07-MAR-12
E	ALTERATION PERMIT	22-MAR-12
F	PRICING	29-APR-12
G	BUILDING PERMIT	01-AUG-12
H	ALTERATION PERMIT REVISIONS	01-NOV-12

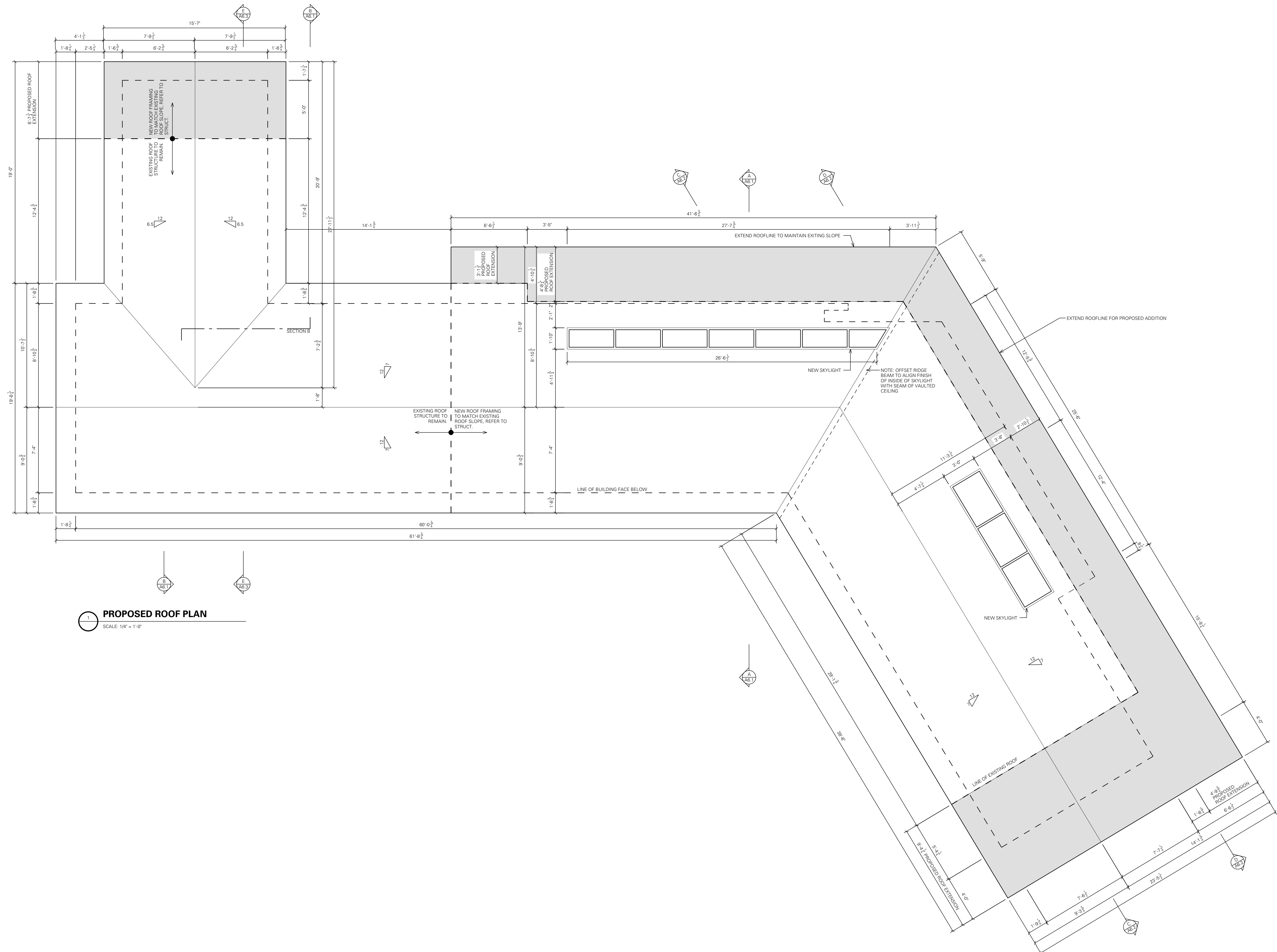

PROPOSED ROOF PLAN
SCALE: 1/4" = 1'-0"

D'ARCY JONES DESIGN INC
204 - 175 Broadway East
Vancouver BC V5T 1W2
T 604 669 2235
F 604 669 2231
E mail@darcyjones.com

SCALE:
1/4" = 1'-0"
DATE:
25-APR-12
DRAWN:
MP
CHECKED:
DJ
REVISION:
ISSUE:
PRICING
CONSULTANT:

Copyright reserved. All parts of this drawing are the exclusive property of D'ARCY JONES DESIGN INC and shall not be used without permission, in part or in whole.
DO NOT SCALE THESE DRAWINGS
All dimensions to be verified by contractor, trades or suppliers. Any discrepancies shall be brought to the attention of the Designer.
Any errors or omissions on this drawing shall be reported to D'ARCY JONES DESIGN INC for clarification and revision.

THE OLD HIGHWAY RENOVATION
4797 HIGHWAY
WEST VANCOUVER BC

A5.1b

PROPOSED ROOF PLAN

ISSUES:		
A	AS-BUILTS	12-OCT-11
B	PLANNING REVIEW	08-FEB-12
C	PLANNING REVIEW	10-FEB-12
D	ALTERATION PERMIT	07-MAR-12
E	ALTERATION PERMIT	22-MAR-12
F	PRICING	25-APR-12
G	BUILDING PERMIT	01-AUG-12
H	ALTERATION PERMIT REVISIONS	01-NOV-12

MATERIALS

- 1 CEDAR SHINGLE ROOFING
- 2 EXISTING ROUGH CUT CEDAR SIDING SEMI-TRANSPARENT STAINED (PATCH AND MAKE GOOD, AS REQUIRED)
- 3 MORTARED GRANITE WALL AND STAIR
- 4 TEMPERED GLASS GUARD
- 5 EXPOSED CONCRETE
- 6 SMOOTH DARK PAINTED CEDAR

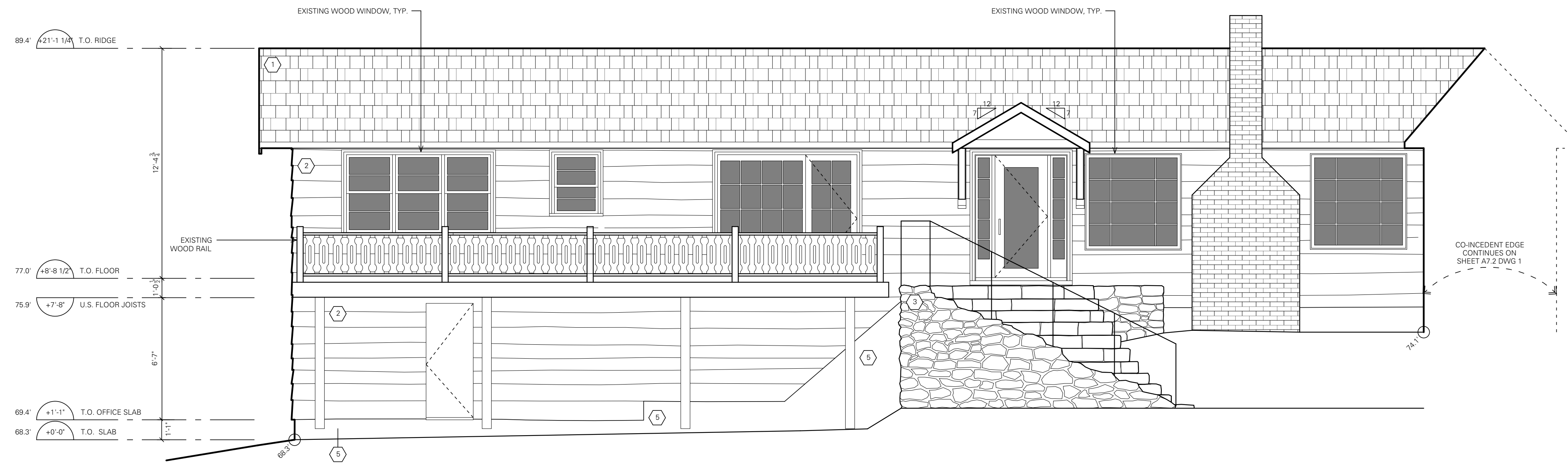

1 EXISTING SOUTH ELEVATION
SCALE: 1/4" = 1'-0"

D'ARCY JONES DESIGN INC

204 - 175 Broadway East
Vancouver BC V5T 1W2
T 604 669 2235
F 604 669 2231
E mail@darcyjones.com

SCALE:
1/4" = 1'-0"
DATE:
25-APR-12
DRAWN:
MP + AK+MKB
CHECKED:
DJ
REVISION:
ISSUE:
PRICING
CONSULTANT:

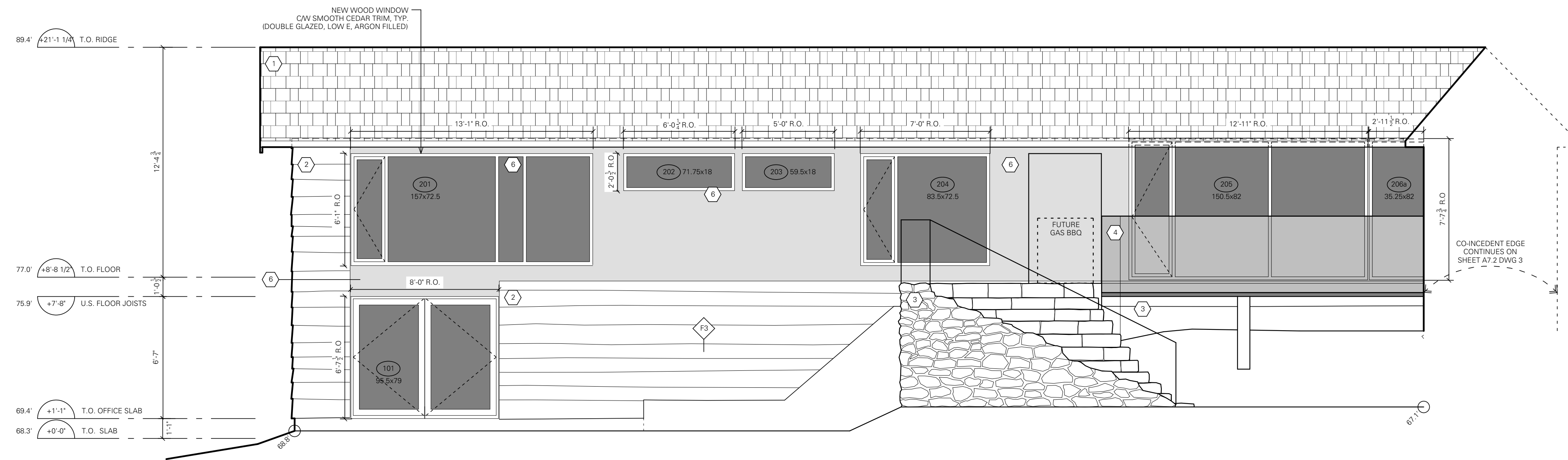

2 PROPOSED SOUTH ELEVATION
SCALE: 1/4" = 1'-0"

Copyright reserved. All parts of this drawing are the exclusive property of D'ARCY JONES DESIGN INC and shall not be used without permission, in part or in whole.
DO NOT SCALE THESE DRAWINGS
All dimensions to be verified by contractor, trades or suppliers. Any discrepancies shall be brought to the attention of the Designer.
Any errors or omissions on this drawing shall be reported to D'ARCY JONES DESIGN INC for clarification and revision.

THE OLD HIGHWAY RENOVATION
4797 HIGHWAY
WEST VANCOUVER BC

A7.1

BUILDING ELEVATIONS

ISSUES:		
A	AS-BUILTS	12-OCT-11
B	PLANNING REVIEW	08-FEB-12
C	PLANNING REVIEW	10-FEB-12
D	ALTERATION PERMIT	07-MAR-12
E	ALTERATION PERMIT	22-MAR-12
F	PRICING	25-APR-12
G	BUILDING PERMIT	01-AUG-12
H	ALTERATION PERMIT REVISIONS	01-NOV-12

MATERIALS

- 1 CEDAR SHINGLE ROOFING
- 2 EXISTING ROUGH CUT CEDAR SIDING SEMI-TRANSPARENT STAINED (PATCH AND MAKE GOOD, AS REQUIRED)
- 3 MORTARED GRANITE WALL AND STAIR
- 4 TEMPERED GLASS GUARD
- 5 EXPOSED CONCRETE
- 6 SMOOTH DARK PAINTED CEDAR

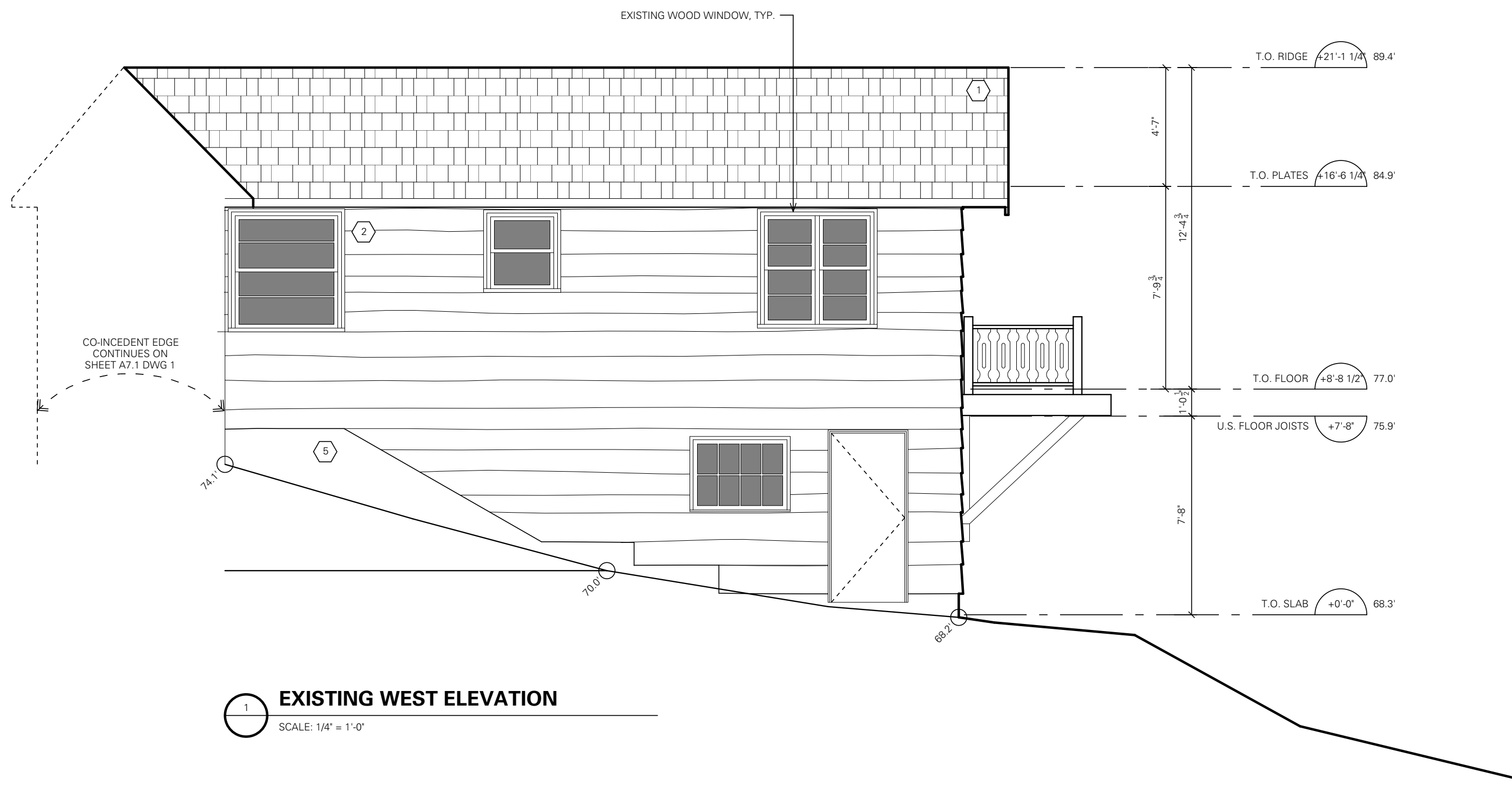

1 EXISTING WEST ELEVATION
SCALE: 1/4" = 1'-0"



1 EXISTING EAST ELEVATION
SCALE: 1/4" = 1'-0"

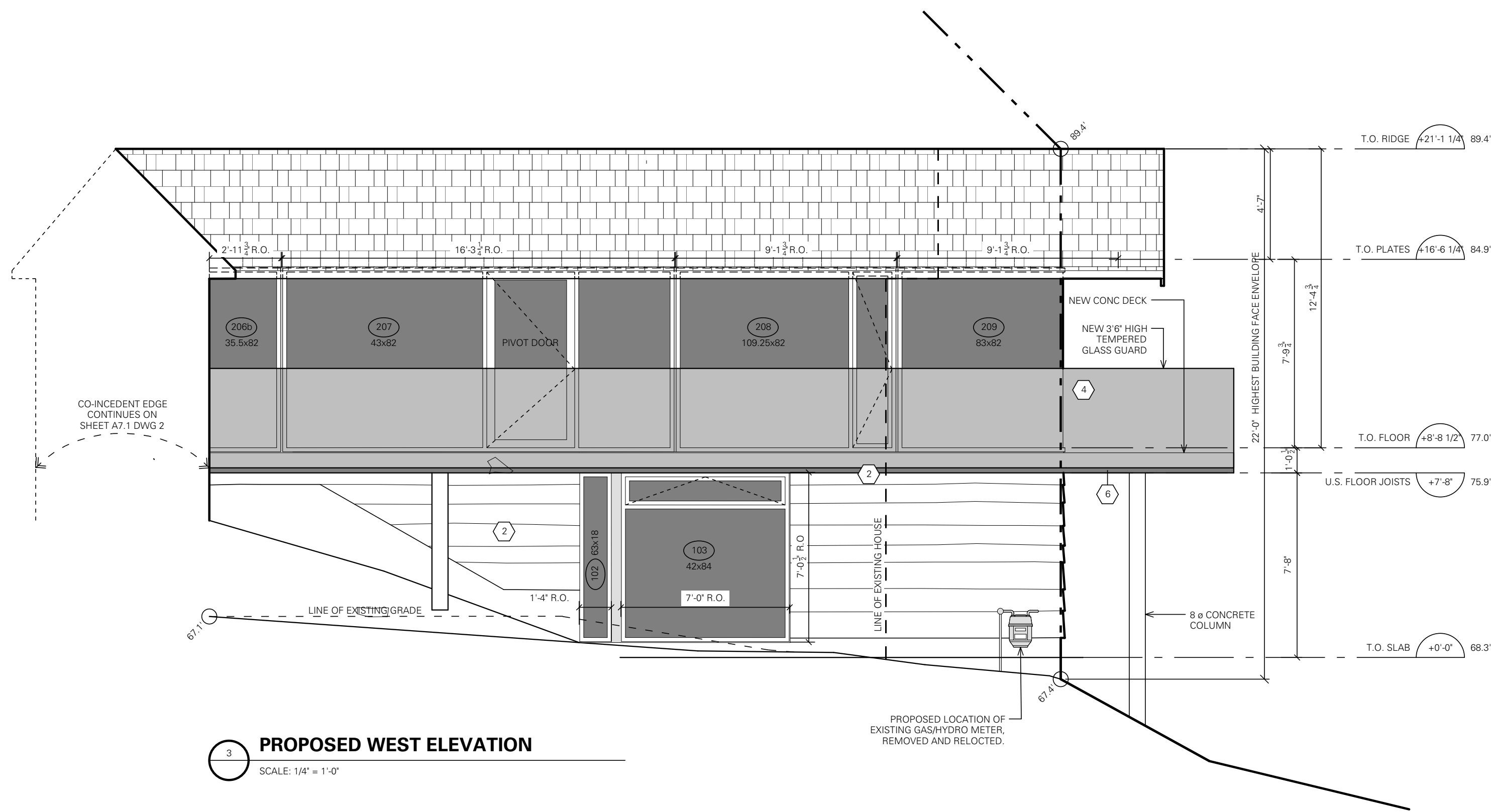

3 PROPOSED WEST ELEVATION
SCALE: 1/4" = 1'-0"

SPATIAL SEPARATION:	
LIMITING DISTANCE:	47'-10" (14.58 m)
MAX ALLOWABLE UNPROTECTED OPENING:	100%
AREA OF EXPOSED BUILDING FACE:	554.8 sq.ft. (51.54 sq.m.)
AREA OF UNPROTECTED OPENING:	526.8 sq.ft. (48.8 sq.m.)
PROPOSED UNPROTECTED OPENING:	94.8%

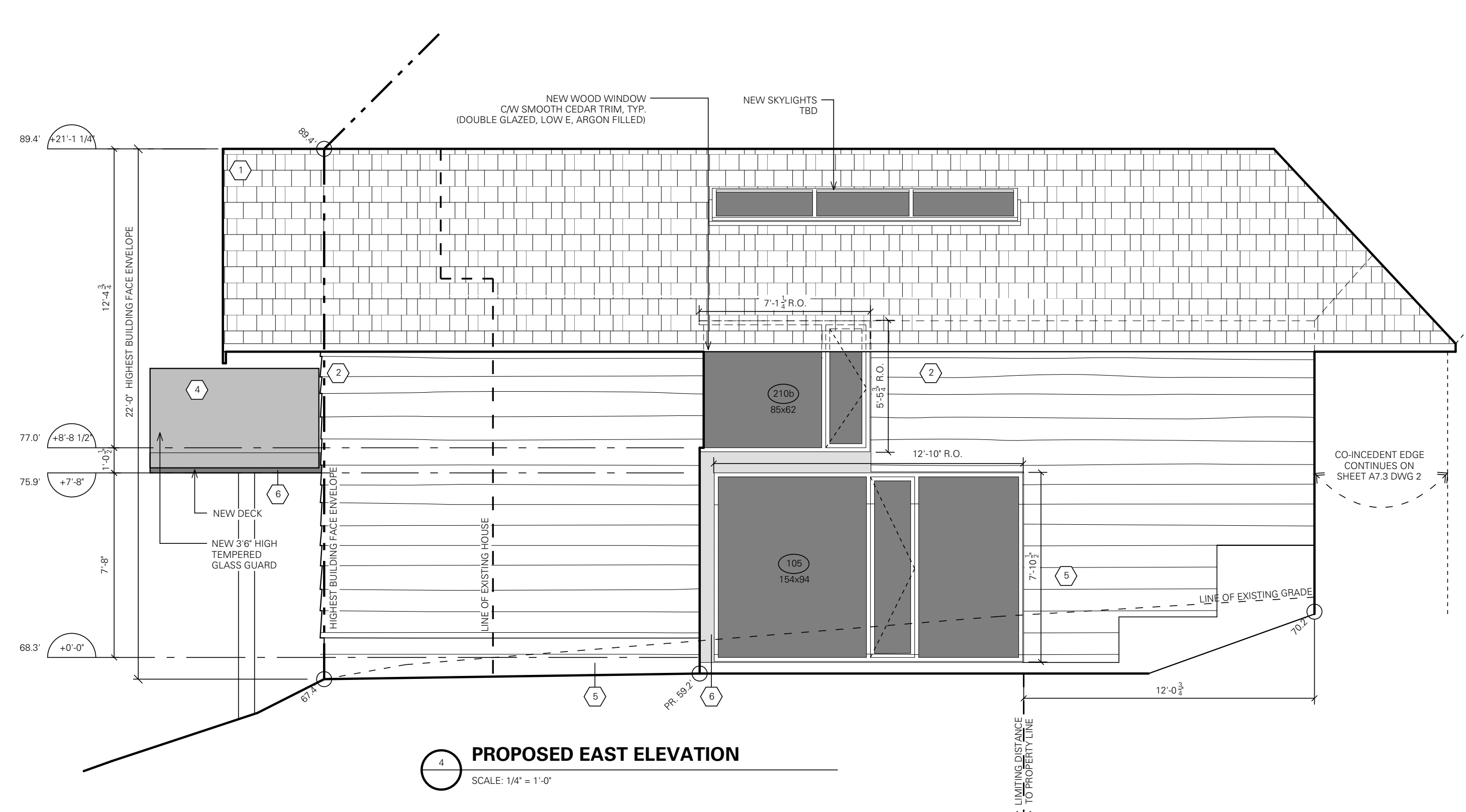

4 PROPOSED EAST ELEVATION
SCALE: 1/4" = 1'-0"

SPATIAL SEPARATION:	
LIMITING DISTANCE:	13'-0" (4.0 m)
MAX ALLOWABLE UNPROTECTED OPENING:	28%
AREA OF EXPOSED BUILDING FACE:	628.4 sq.ft. (58.4 sq.m.)
AREA OF UNPROTECTED OPENING:	176.0 sq.ft. (16.3 sq.m.)
PROPOSED UNPROTECTED OPENING:	28.0%

D'ARCY JONES DESIGN INC

204 - 175 Broadway East
Vancouver BC V5T 1W2
T 604 669 2235
F 604 669 2231
E mail@darcyjones.com

SCALE:
1/4" = 1'-0"
DATE:
25-APR-12
DRAWN:
MP + AK + MKB
CHECKED:
DJ
REVISION:
ISSUE:
PRICING
CONSULTANT:

Copyright reserved. All parts of this drawing are the exclusive property of D'ARCY JONES DESIGN INC and shall not be used without permission, in part or in whole.
DO NOT SCALE THESE DRAWINGS
All dimensions to be verified by contractor, trades or suppliers. Any discrepancies shall be brought to the attention of the Designer.
Any errors or omissions on this drawing shall be reported to D'ARCY JONES DESIGN INC for clarification and revision.

THE OLD HIGHWAY RENOVATION
4797 HIGHWAY
WEST VANCOUVER BC

A7.2

BUILDING ELEVATIONS

ISSUES:		
A	AS-BUILTS	12-OCT-11
B	PLANNING REVIEW	08-FEB-12
C	PLANNING REVIEW	10-FEB-12
D	ALTERATION PERMIT	07-MAR-12
E	ALTERATION PERMIT	22-MAR-12
F	PRICING	25-APR-12
G	BUILDING PERMIT	01-AUG-12
H	ALTERATION PERMIT REVISION	01-NOV-12

MATERIALS

- ① CEDAR SHINGLE ROOFING
- ② EXISTING ROUGH CUT CEDAR SIDING (PATCH AND MAKE GOOD, AS REQUIRED)
- ③ MORTARED GRANITE WALL AND STAIR
- ④ TEMPERED GLASS GUARD
- ⑤ EXPOSED CONCRETE
- ⑥ SMOOTH DARK PAINTED CEDAR

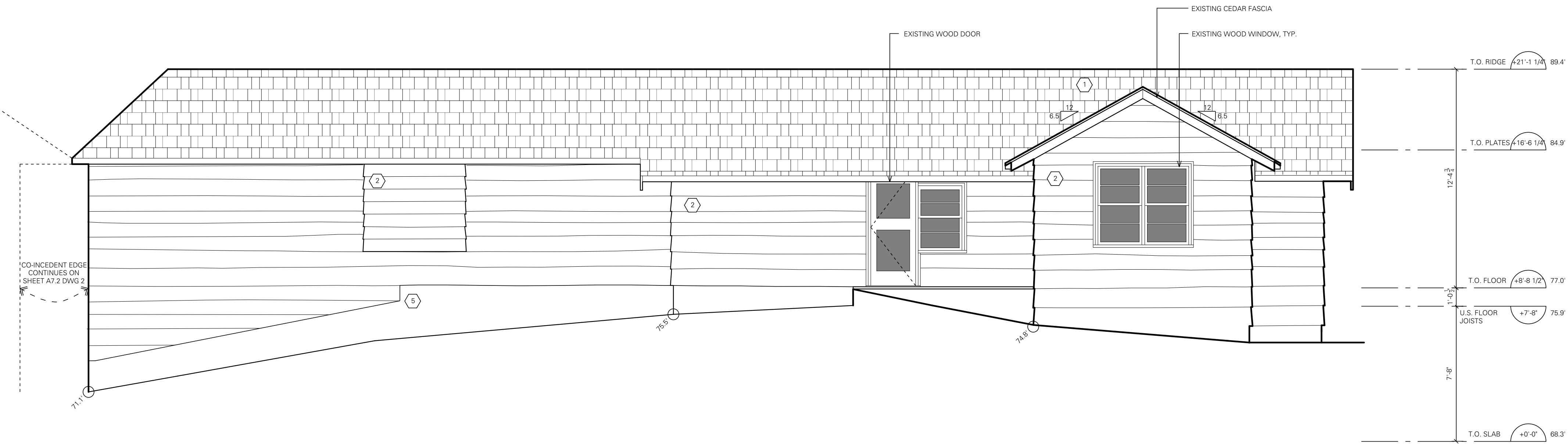

1 EXISTING NORTH ELEVATION
SCALE: 1/4" = 1'-0"

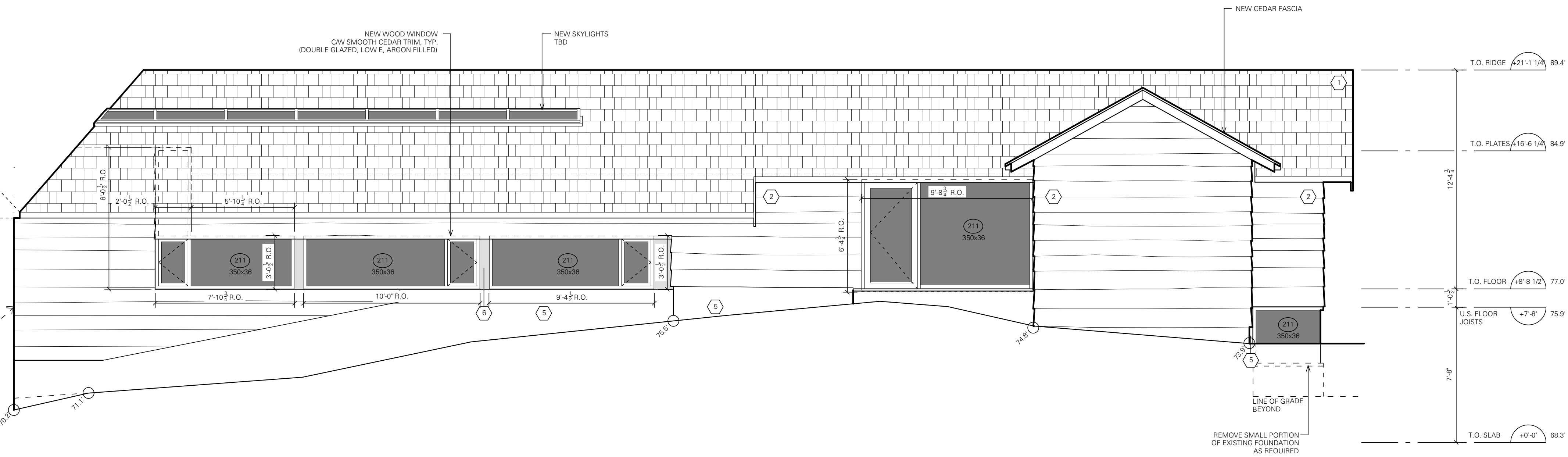
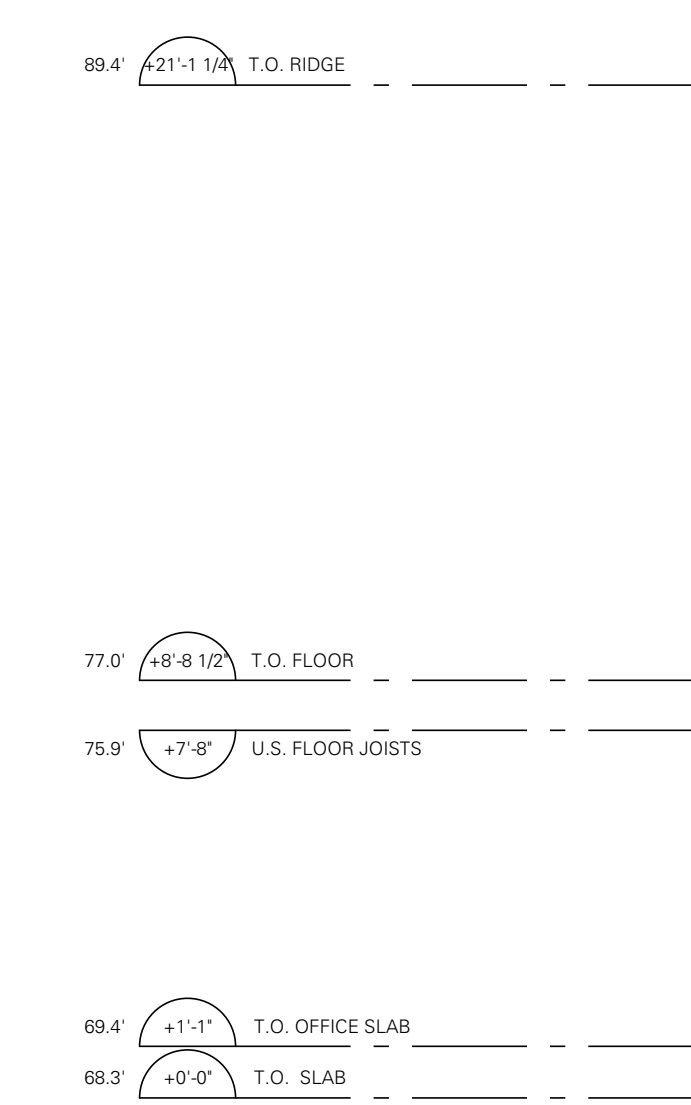

2 PROPOSED NORTH ELEVATION
SCALE: 1/4" = 1'-0"

D'ARCY JONES DESIGN INC

204 - 175 Broadway East
Vancouver BC V5T 1W2
T 604 669 2235
F 604 669 2231
E mail@darcyjones.com

SCALE:
1/4" = 1'-0"
DATE:
25-APR-12
DRAWN:
MP + AK + MKB
CHECKED:
DJ
REVISION:
ISSUE:
PRICING
CONSULTANT:

Copyright reserved. All parts of this drawing are the exclusive property of D'ARCY JONES DESIGN INC and shall not be used without permission, in part or in whole.
DO NOT SCALE THESE DRAWINGS
All dimensions to be verified by contractor, trades or suppliers. Any discrepancies shall be brought to the attention of the Designer.
Any errors or omissions on this drawing shall be reported to D'ARCY JONES DESIGN INC for clarification and revision.

THE OLD HIGHWAY RENOVATION
4797 HIGHWAY
WEST VANCOUVER BC

A7.3

BUILDING ELEVATIONS

ISSUES:		
A	AS-BUILTS	12-OCT-11
B	PLANNING REVIEW	08-FEB-12
C	PLANNING REVIEW	10-FEB-12
D	ALTERATION PERMIT	07-MAR-12
E	ALTERATION PERMIT	22-MAR-12
F	PRICING	25-APR-12
G	BUILDING PERMIT	01-AUG-12
H	ALTERATION PERMIT REVISIONS	01-NOV-12

MATERIALS

- 1 CEDAR SHINGLE ROOFING
- 2 EXISTING ROUGH CUT CEDAR SIDING SEMI-TRANSPARENT STAINED (PATCH AND MAKE GOOD, AS REQUIRED)
- 3 MORTARED GRANITE WALL AND STAIR
- 4 TEMPERED GLASS GUARD
- 5 EXPOSED CONCRETE
- 6 SMOOTH DARK PAINTED CEDAR

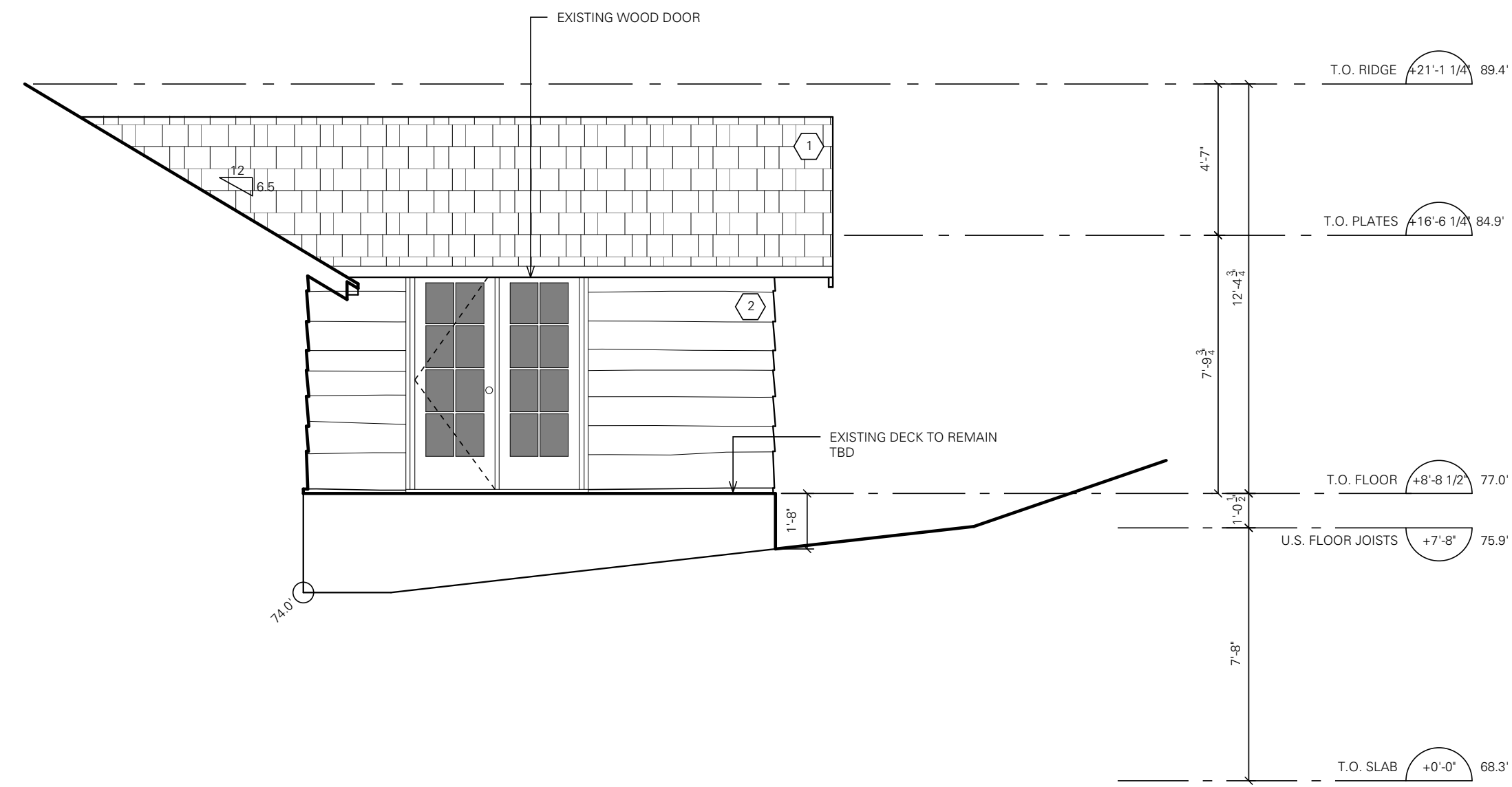

1 EXISTING SOUTHEAST ELEVATION
SCALE: 1/4" = 1'-0"

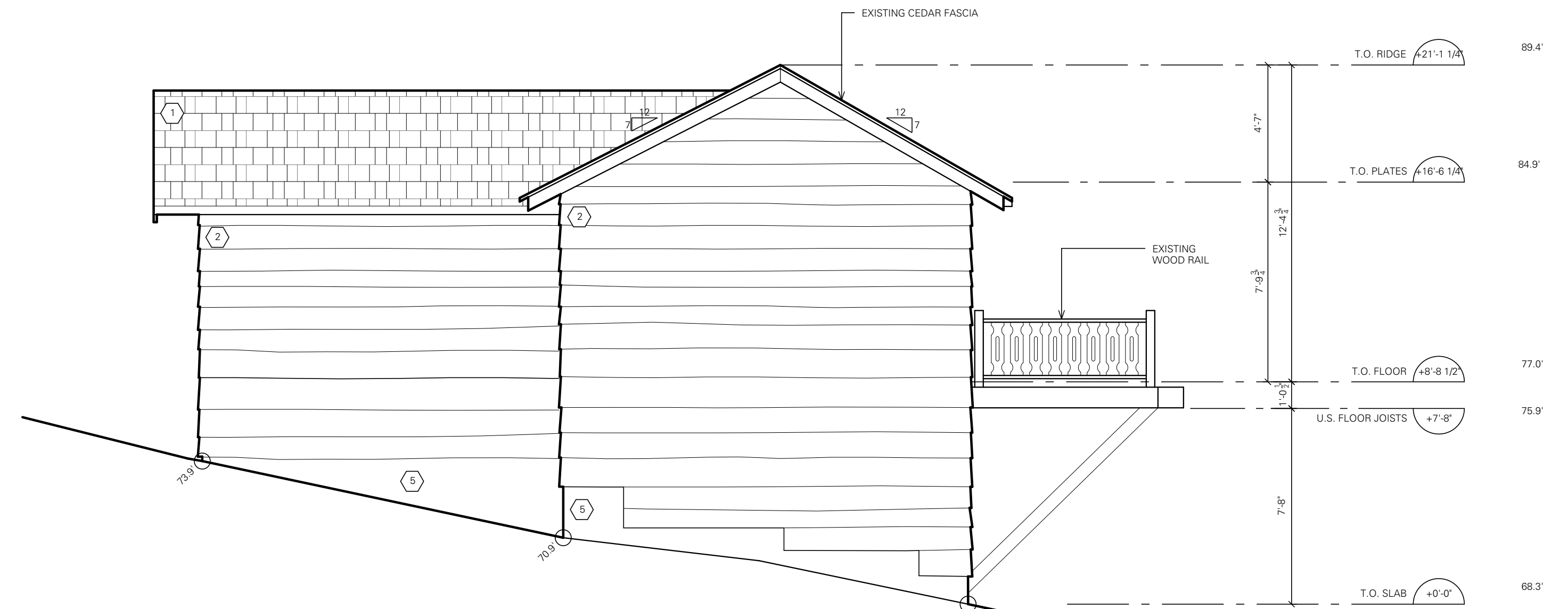

2 EXISTING NORTHWEST ELEVATION
SCALE: 1/4" = 1'-0"

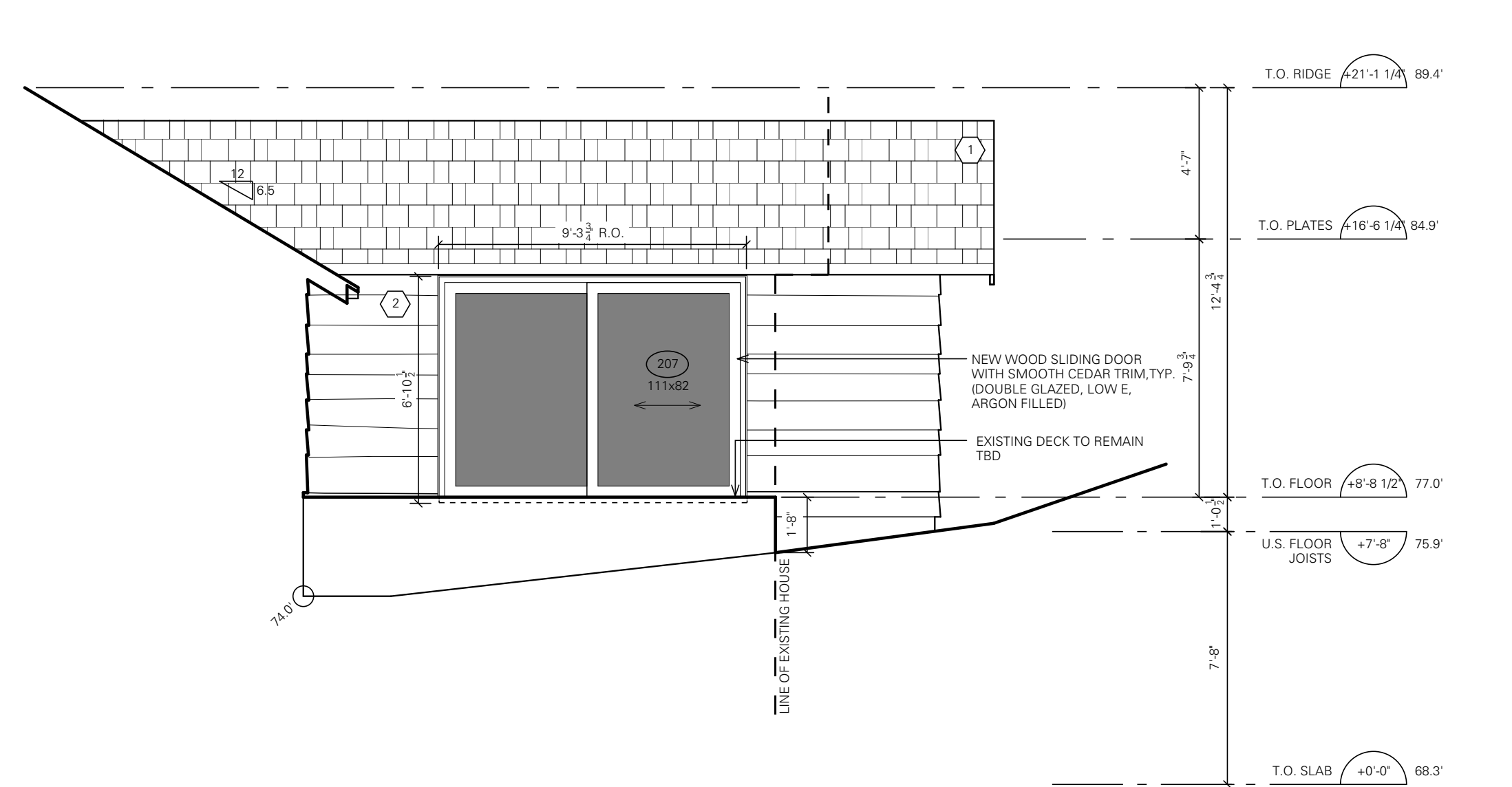

3 PROPOSED SOUTHEAST ELEVATION
SCALE: 1/4" = 1'-0"

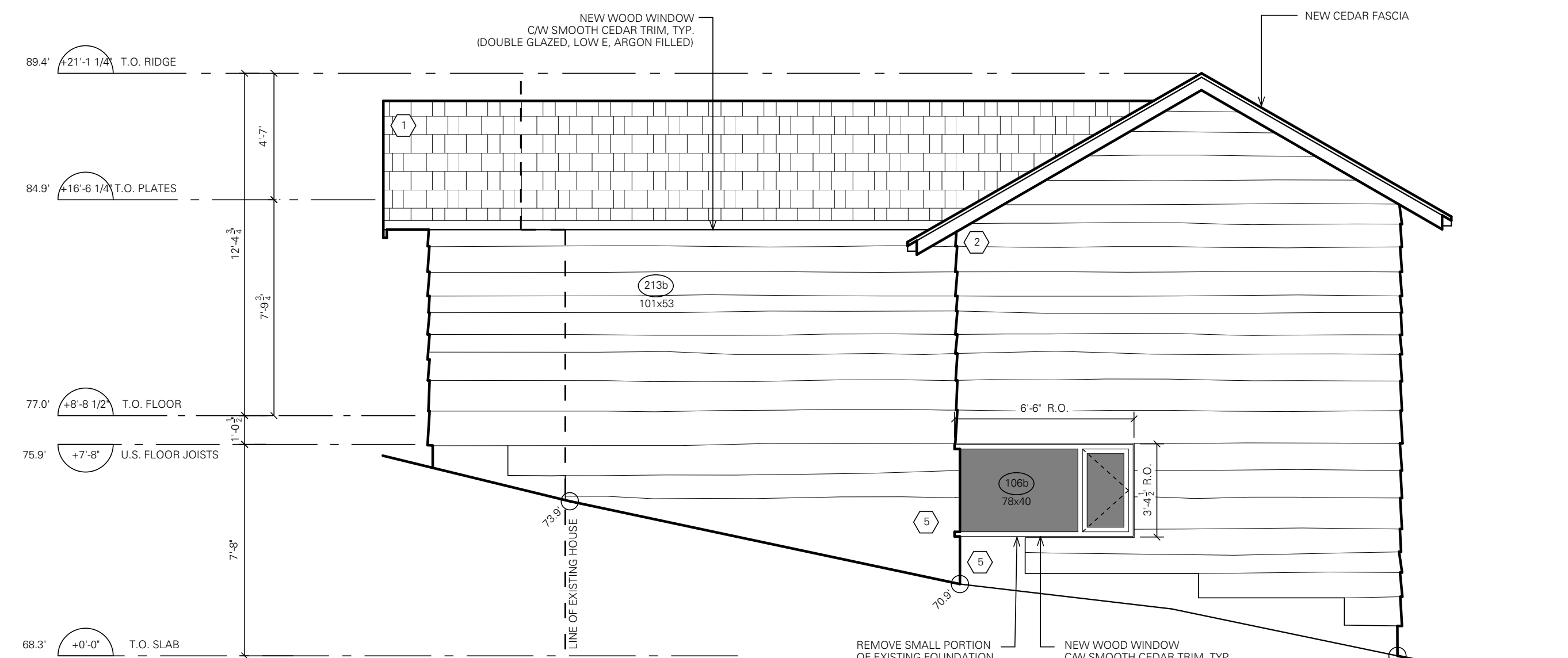

4 PROPOSED NORTHWEST ELEVATION
SCALE: 1/4" = 1'-0"

D'ARCY JONES DESIGN INC

204 - 175 Broadway East
Vancouver BC V5T 1W2
T 604 669 2235
F 604 669 2231
E mail@darcyjones.com

SCALE:
1/4" = 1'-0"
DATE:
25-APR-12
DRAWN:
MP + AK + MKB
CHECKED:
DJ
REVISION:
ISSUE:
PRICING
CONSULTANT:

Copyright reserved. All parts of this drawing are the exclusive property of D'ARCY JONES DESIGN INC and shall not be used without permission, in part or in whole.
DO NOT SCALE THESE DRAWINGS
All dimensions to be verified by contractor, trades or suppliers. Any discrepancies shall be brought to the attention of the Designer.
Any errors or omissions on this drawing shall be reported to D'ARCY JONES DESIGN INC for clarification and revision.

THE OLD HIGHWAY RENOVATION
4797 HIGHWAY
WEST VANCOUVER BC

A7.4

BUILDING ELEVATIONS

ISSUES:		
A	AS-BUILTS	12-OCT-11
B	PLANNING REVIEW	08-FEB-12
C	PLANNING REVIEW	10-FEB-12
D	ALTERATION PERMIT	07-MAR-12
E	ALTERATION PERMIT	22-MAR-12
F	PRICING	25-APR-12
G	BUILDING PERMIT	01-AUG-12
H	ALTERATION PERMIT REVISIONS	01-NOV-12

MATERIALS

- ① CEDAR SHINGLE ROOFING
- ② EXISTING ROUGH CUT CEDAR SIDING SEMI-TRANSPARENT STAINED (PATCH AND MAKE GOOD, AS REQUIRED)
- ③ MORTARED GRANITE WALL AND STAIR
- ④ TEMPERED GLASS GUARD
- ⑤ EXPOSED CONCRETE
- ⑥ SMOOTH DARK PAINTED CEDAR



1 EXISTING SOUTH ELEVATION
SCALE: 1/4" = 1'-0"

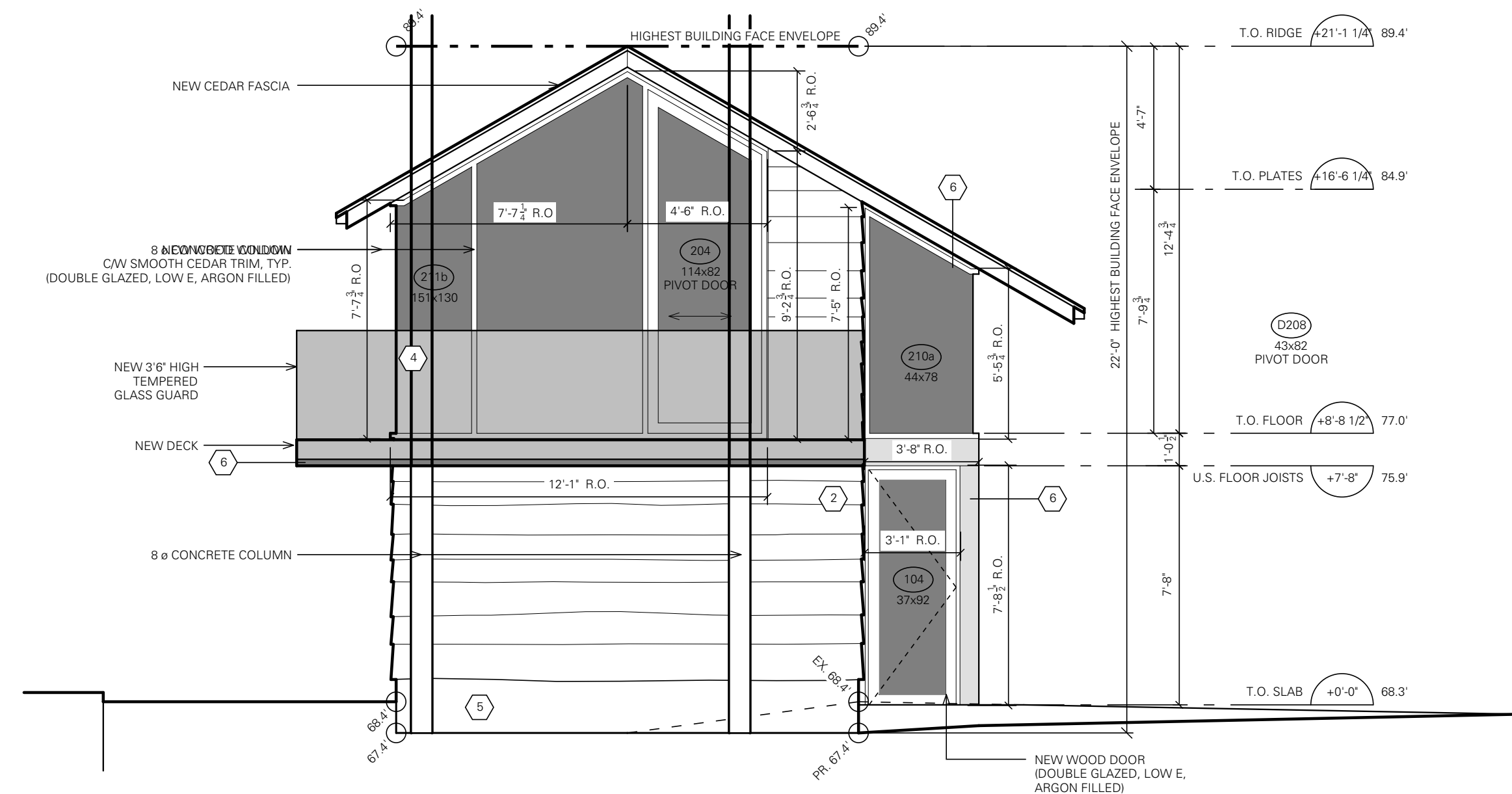

2 PROPOSED SOUTH ELEVATION
SCALE: 1/4" = 1'-0"

D'ARCY JONES DESIGN INC

204 - 175 Broadway East
Vancouver BC V5T 1W2
T 604 669 2235
F 604 669 2231
E mail@darcyjones.com

SCALE:
1/4" = 1'-0"
DATE:
25-APR-12
DRAWN:
MP + AK + MKB
CHECKED:
DJ
REVISION:
ISSUE:
PRICING
CONSULTANT:

Copyright reserved. All parts of this drawing are the exclusive property of D'ARCY JONES DESIGN INC and shall not be used without permission, in part or in whole.
DO NOT SCALE THESE DRAWINGS
All dimensions to be verified by contractor, trades or suppliers. Any discrepancies shall be brought to the attention of the Designer.
Any errors or omissions on this drawing shall be reported to D'ARCY JONES DESIGN INC for clarification and revision.

THE OLD HIGHWAY RENOVATION
4797 HIGHWAY
WEST VANCOUVER BC

A7.5

ISSUES:		
A	AS-BUILTS	12-OCT-11
B	PLANNING REVIEW	08-FEB-12
C	PLANNING REVIEW	10-FEB-12
D	ALTERATION PERMIT	07-MAR-12
E	ALTERATION PERMIT	22-MAR-12
F	PRICING	25-APR-12
G	BUILDING PERMIT	01-AUG-12
H	ALTERATION PERMIT REVISIONS	01-NOV-12

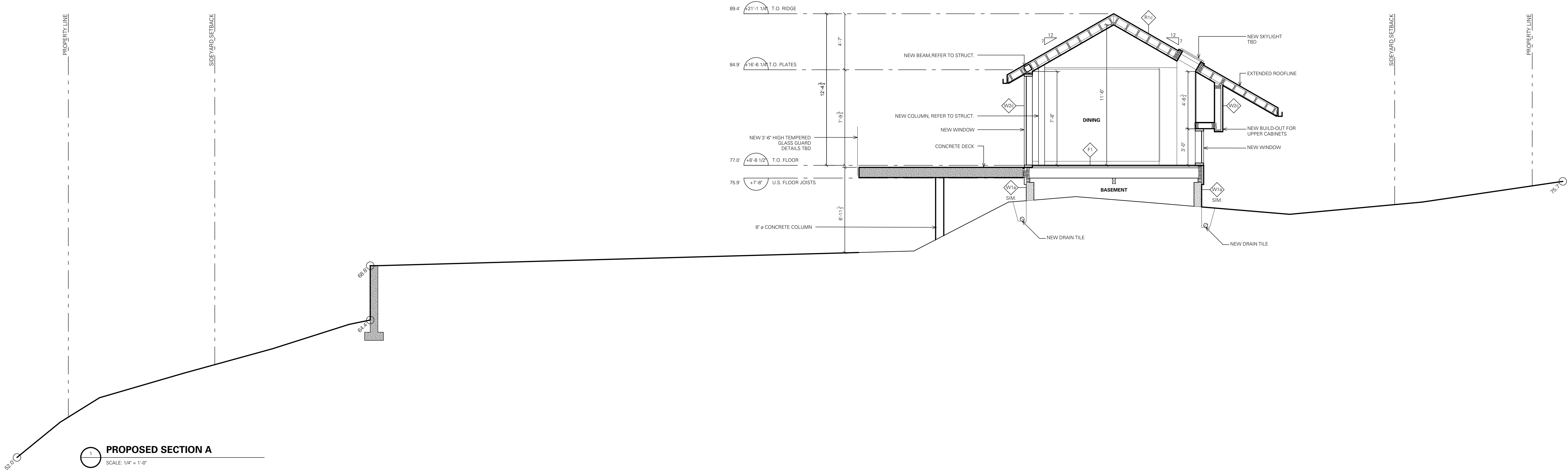

PROPOSED SECTION A
SCALE: 1/4" = 1'-0"

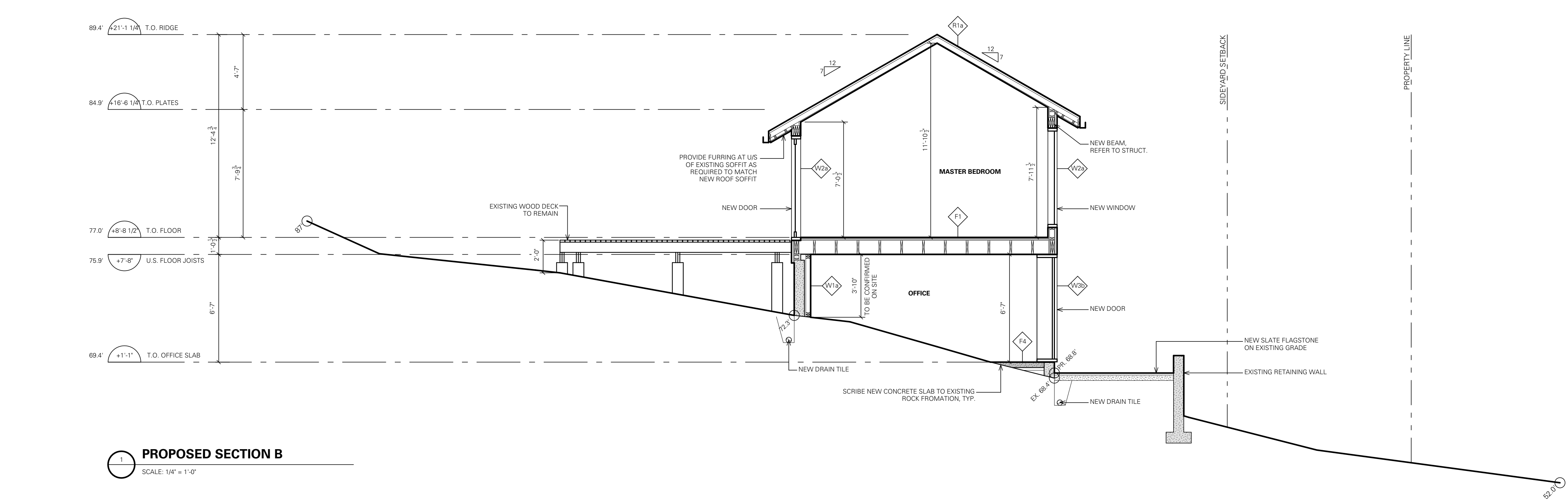

PROPOSED SECTION B
SCALE: 1/4" = 1'-0"

D'ARCY JONES DESIGN INC
204 - 175 Broadway East
Vancouver BC V5T 1W2
T 604 669 2235
F 604 669 2231
E mail@darcyjones.com

SCALE:
1/4" = 1'-0"
DATE:
25-APR-12
DRAWN:
MP + AK + MKB
CHECKED:
DJ
REVISION:
-
ISSUE:
PRICING
CONSULTANT:
-

Copyright reserved. All parts of this drawing are the exclusive property of D'ARCY JONES DESIGN INC and shall not be used without permission, in part or in whole.
DO NOT SCALE THESE DRAWINGS
All dimensions to be verified by contractor, trades or suppliers. Any discrepancies shall be brought to the attention of the Designer.
Any errors or omissions on this drawing shall be reported to D'ARCY JONES DESIGN INC for clarification and revision.

THE OLD HIGHWAY RENOVATION
4797 HIGHWAY
WEST VANCOUVER BC

A6.1

ISSUES:		
A	AS-BUILTS	12-OCT-11
B	PLANNING REVIEW	08-FEB-12
C	PLANNING REVIEW	10-FEB-12
D	ALTERATION PERMIT	07-MAR-12
E	ALTERATION PERMIT	22-MAR-12
F	PRICING	25-APR-12
G	BUILDING PERMIT	01-AUG-12
H	ALTERATION PERMIT REVISIONS	01-NOV-12

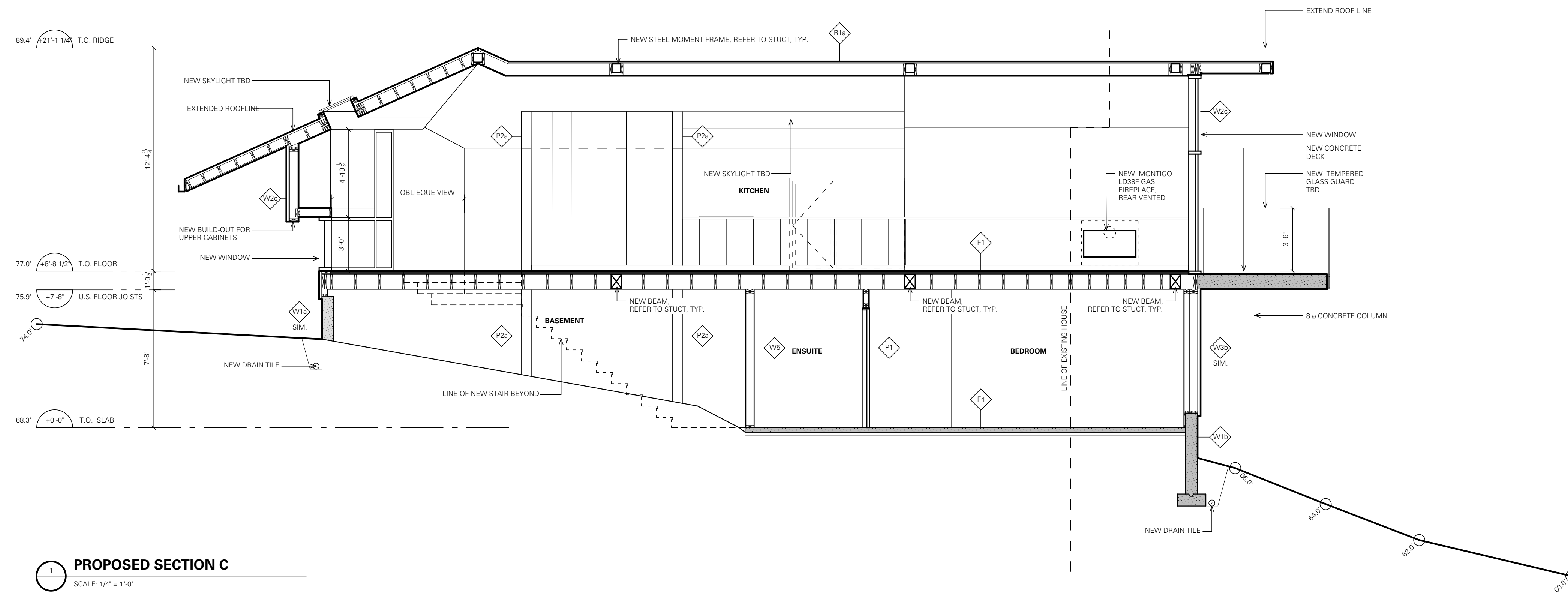

1 PROPOSED SECTION C
SCALE: 1/4" = 1'-0"

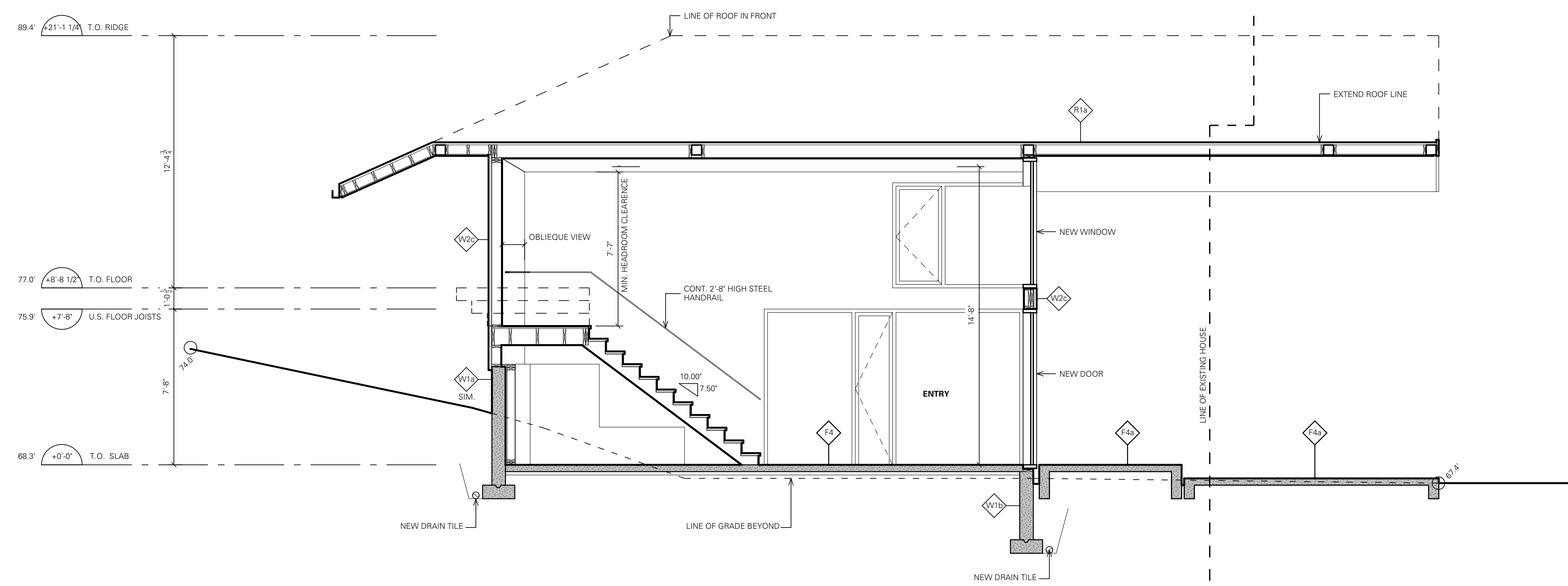

2 PROPOSED SECTION D
SCALE: 1/4" = 1'-0"

D'ARCY JONES DESIGN INC

204 - 175 Broadway East
Vancouver BC V5T 1W2
T 604 669 2235
F 604 669 2231
E mail@darcyjones.com

SCALE:
1/4" = 1'-0"
DATE:
25-APR-12
DRAWN:
MKB
CHECKED:
DJ
REVISION:
ISSUE:
PRICING
CONSULTANT:

Copyright reserved. All parts of this drawing are the exclusive property of D'ARCY JONES DESIGN INC and shall not be used without permission, in part or in whole.
DO NOT SCALE THESE DRAWINGS
All dimensions to be verified by contractor, trades or suppliers. Any discrepancies shall be brought to the attention of the Designer.
Any errors or omissions on this drawing shall be reported to D'ARCY JONES DESIGN INC for clarification and revision.

THE OLD HIGHWAY RENOVATION
4797 HIGHWAY
WEST VANCOUVER BC

A6.2

BUILDING SECTIONS

ISSUES:		
A	AS-BUILTS	12-OCT-11
B	PLANNING REVIEW	08-FEB-12
C	PLANNING REVIEW	10-FEB-12
D	ALTERATION PERMIT	07-MAR-12
E	ALTERATION PERMIT	22-MAR-12
F	PRICING	25-APR-12
G	BUILDING PERMIT	01-AUG-12
H	ALTERATION PERMIT REVISIONS	01-NOV-12

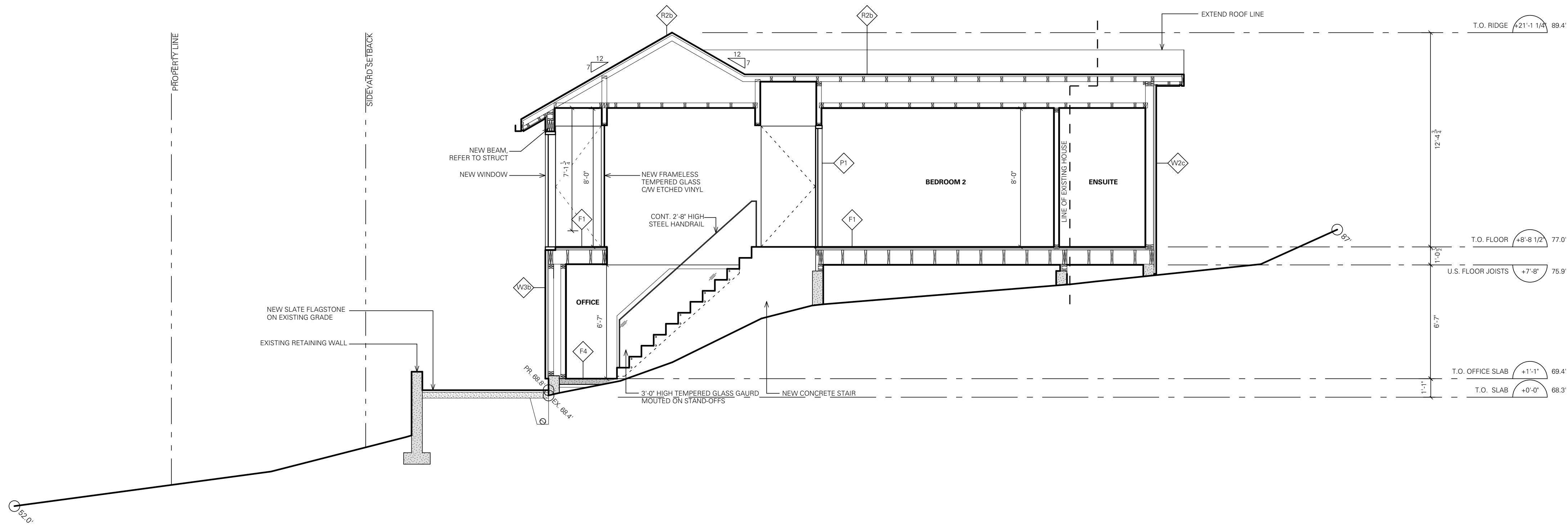

PROPOSED SECTION E
SCALE: 1/4" = 1'-0"

D'ARCY JONES DESIGN INC
204 - 175 Broadway East
Vancouver BC V5T 1W2
T 604 669 2235
F 604 669 2231
E mail@darcyjones.com

SCALE:
1/4" = 1'-0"
DATE:
25-APR-12
DRAWN:
MKB
CHECKED:
DJ
REVISION:
-
ISSUE:
PRICING
CONSULTANT:
-

Copyright reserved. All parts of this drawing are the exclusive property of D'ARCY JONES DESIGN INC and shall not be used without permission, in part or in whole.
DO NOT SCALE THESE DRAWINGS
All dimensions to be verified by contractor, trades or suppliers. Any discrepancies shall be brought to the attention of the Designer.
Any errors or omissions on this drawing shall be reported to D'ARCY JONES DESIGN INC for clarification and revision.

THE OLD HIGHWAY RENOVATION
4797 HIGHWAY
WEST VANCOUVER BC

A6.3

BUILDING SECTIONS

1 WALL ASSEMBLY SCHEDULE

SCALE: 1 1/2" = 1'-0"

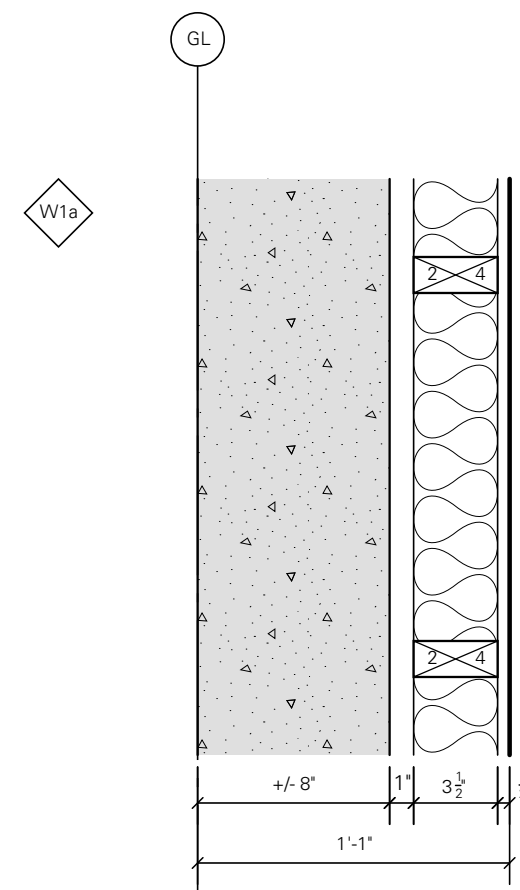

- W1a - EXISTING FOUNDATION WALL**
- 4" 8" CONCRETE WALL
 - 1" AIR SPACE
 - NEW 2x4 STUDS @ 16" O.C.
 - NEW MIN. R-20 BATT INSULATION
 - NEW 1/2" PAINTED DRYWALL

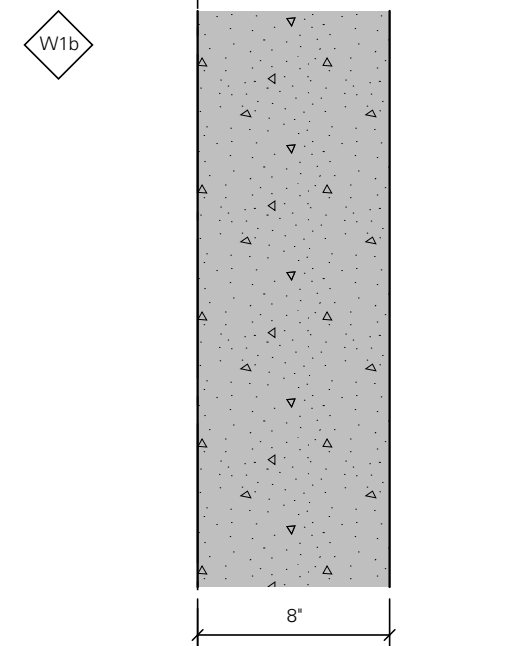

- W1b - NEW FOUNDATION WALL**
- WATERPROOFING MEMBRANE
 - 8" CONCRETE WALL
 - REINFORCEMENT AS PER STRUCTURAL

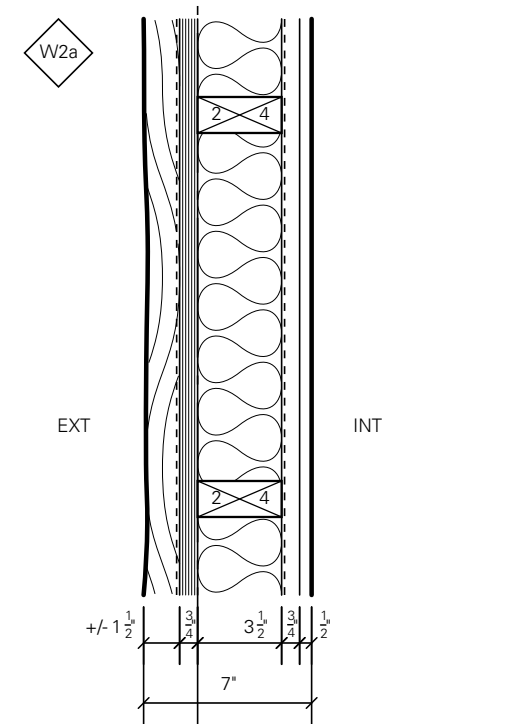

- W2a - NEW EXT. WALL W/ WOOD SIDING TO MATCH EXISTING**
- EXISTING +/- 1 1/2" x 9" HORIZONTAL WOOD SIDING (PATCH AND MAKE GOOD WHERE REQUIRED)
 - EXISTING BUILDING PAPER
 - EXISTING 3/4" SHIPLAP
 - EXISTING 2x4 STUDS @ 16" O.C.
 - NEW MIN. R-14 FIBERGLASS BATT INSULATION
 - NEW 6 MIL POLY VAPOUR RETARDER TAPED & SEALED
 - NEW 3/4" STRAPPING
 - NEW 1/2" PAINTED GYPSUM WALL BOARD TAPED & SANDED

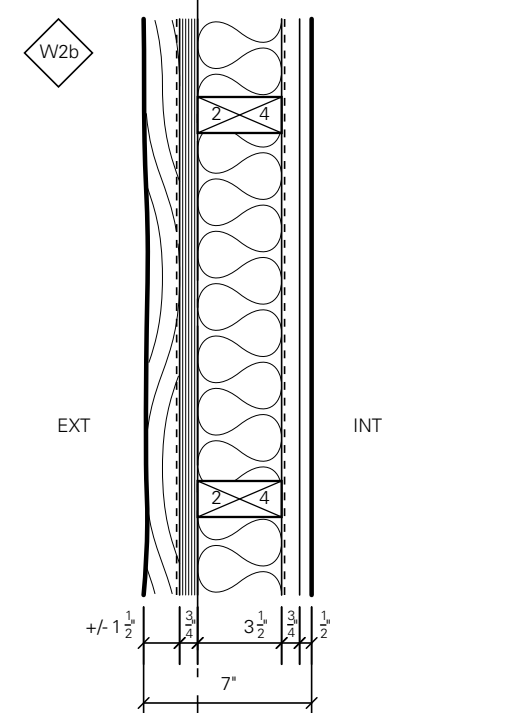

- W2b - EXISTING EXT. WALL W/ WOOD SIDING**
- SALVAGED +/- 1 1/2" x 9" HORIZONTAL WOOD SIDING
 - NEW 2 LAYERS 30 MIN. BUILDING PAPER
 - NEW 3/4" EXTERIOR GRADE PLYWOOD
 - NEW 2x4 STUDS @ 16" O.C.
 - NEW MIN. R-14 FIBERGLASS BATT INSULATION
 - NEW 6 MIL POLY VAPOUR RETARDER TAPED & SEALED
 - NEW 3/4" STRAPPING
 - NEW 1/2" PAINTED GYPSUM WALL BOARD TAPED & SANDED

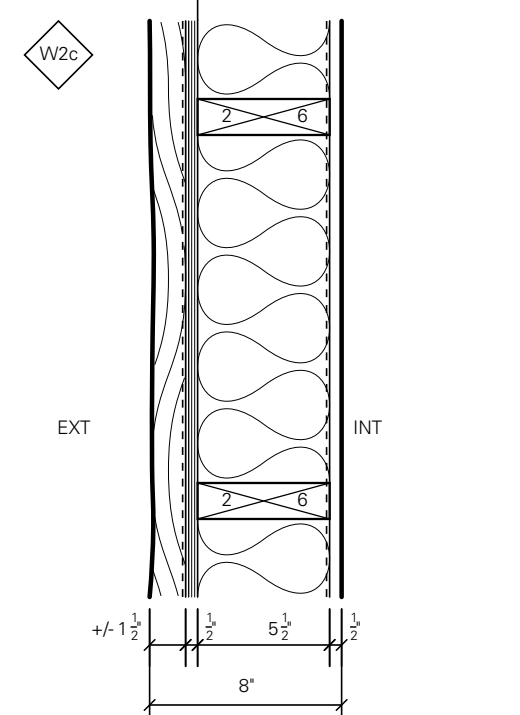

- W2c - NEW EXT. WALL W/ WOOD SIDING**
- SALVAGED +/- 1 1/2" x 9" HORIZONTAL WOOD SIDING
 - NEW 2 LAYERS 30 MIN. BUILDING PAPER
 - NEW 3/4" EXTERIOR GRADE PLYWOOD
 - NEW 2x4 STUDS @ 16" O.C.
 - NEW MIN. R-14 FIBERGLASS BATT INSULATION
 - NEW 6 MIL POLY VAPOUR RETARDER TAPED & SEALED
 - NEW 3/4" STRAPPING
 - NEW 1/2" PAINTED GYPSUM WALL BOARD TAPED & SANDED

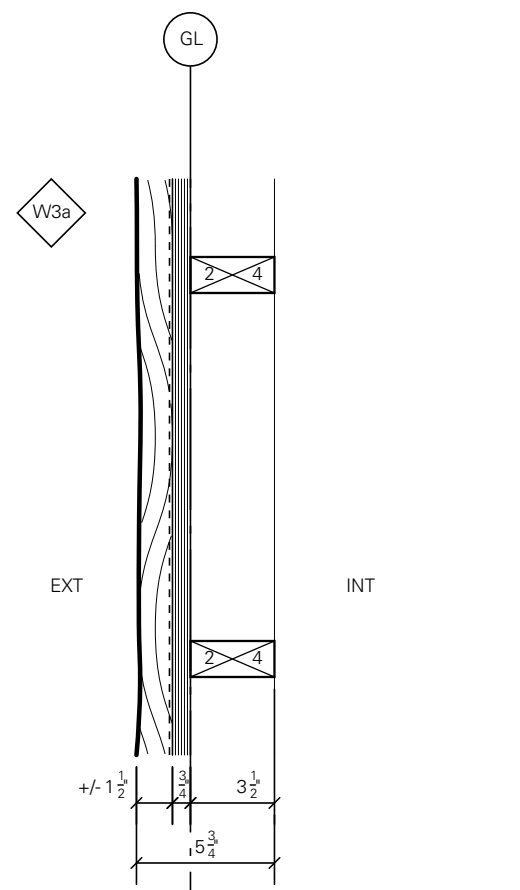

- W3a - EXT. CRAWLSPACE WALL W/ WOOD SIDING**
- EXISTING +/- 1 1/2" x 9" HORIZONTAL WOOD SIDING (PATCH AND MAKE GOOD WHERE REQUIRED)
 - EXISTING BUILDING PAPER
 - EXISTING 3/4" SHIPLAP
 - EXISTING 2x4 STUDS @ 16" O.C.

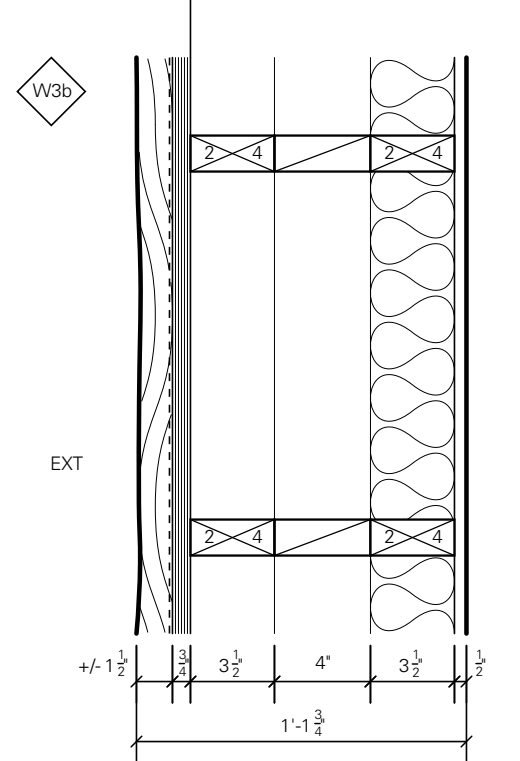

- W3b - EXT. CRAWLSPACE WALL W/ WOOD SIDING AND FURRING**
- EXISTING +/- 1 1/2" x 9" HORIZONTAL WOOD SIDING (PATCH AND MAKE GOOD WHERE REQUIRED)
 - EXISTING BUILDING PAPER
 - EXISTING 3/4" SHIPLAP
 - EXISTING 2x4 STUDS @ 16" O.C.
 - NEW FURRING TO SUIT
 - NEW 2x4 STUDS @ 16" O.C.
 - NEW MIN. R-26 FIBERGLASS BATT INSULATION
 - NEW 1/2" PAINTED GYPSUM WALL BOARD TAPED & SANDED

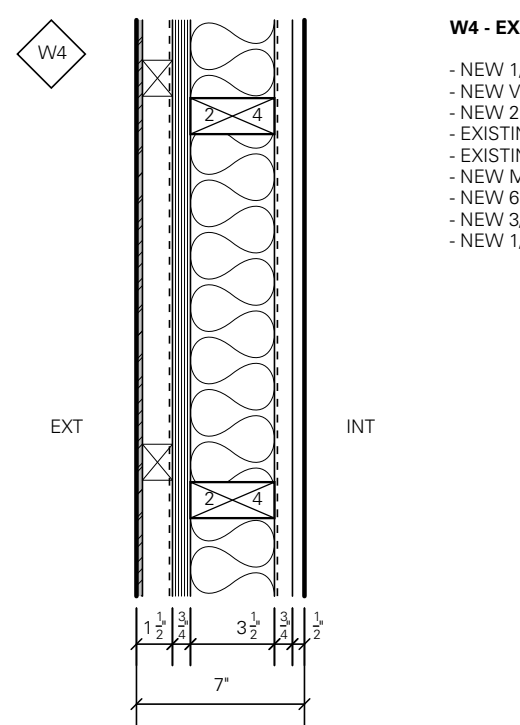

- W4 - EXT. WALL W/ METAL PANEL**
- NEW 1/4" METAL PANEL TBD
 - NEW VERT. PT STRAPPING TO SUIT
 - NEW 2 LAYERS 30 MIN. BUILDING PAPER
 - EXISTING 3/4" SHIPLAP
 - EXISTING 2x4 STUDS @ 16" O.C.
 - NEW MIN. R-14 FIBERGLASS BATT INSULATION
 - NEW 6 MIL POLY VAPOUR RETARDER TAPED & SEALED
 - NEW 3/4" STRAPPING
 - NEW 1/2" PAINTED GYPSUM WALL BOARD TAPED & SANDED

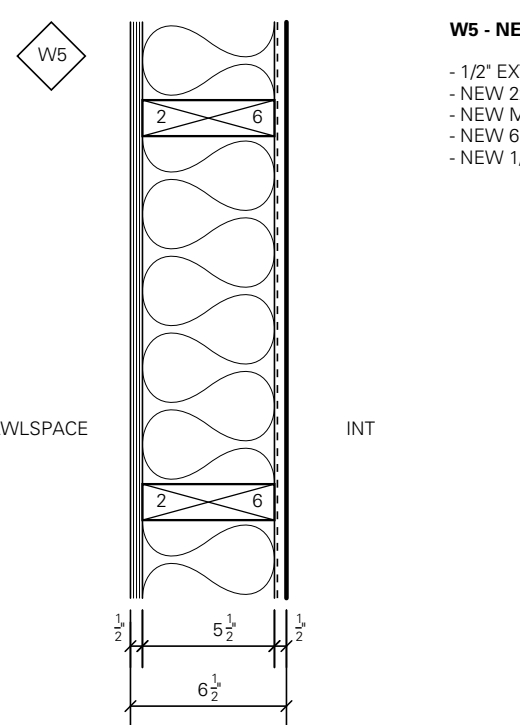

- W5 - NEW INT. @ BASEMENT CRAWLSPACE**
- 1/2" EXTERIOR GRADE PLYWOOD
 - NEW 2x4 STUDS @ 16" O.C.
 - NEW MIN. R-26 FIBERGLASS BATT INSULATION
 - NEW 6 MIL POLY VAPOUR RETARDER TAPED & SEALED
 - NEW 1/2" PAINTED GYPSUM WALL BOARD TAPED & SANDED

2 PARTITION ASSEMBLY SCHEDULE

SCALE: 1 1/2" = 1'-0"

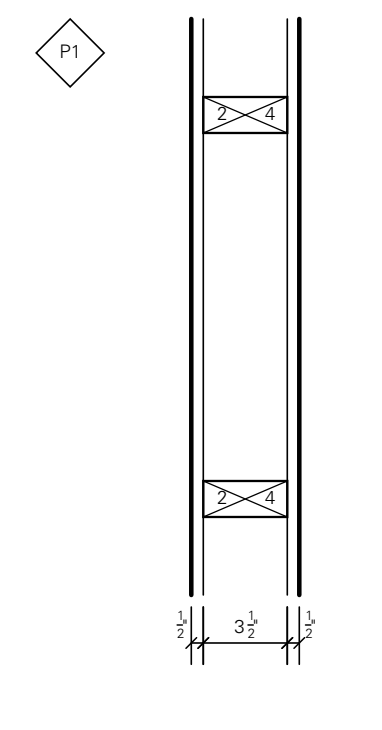

- P1 - TYP. PARTITION**
- 1/2" PAINTED GYPSUM WALL BOARD TAPED & SANDED
 - 2x4 STUDS @ 16" O.C. AS PER STRUCT.
 - 1/2" PAINTED GYPSUM WALL BOARD TAPED & SANDED

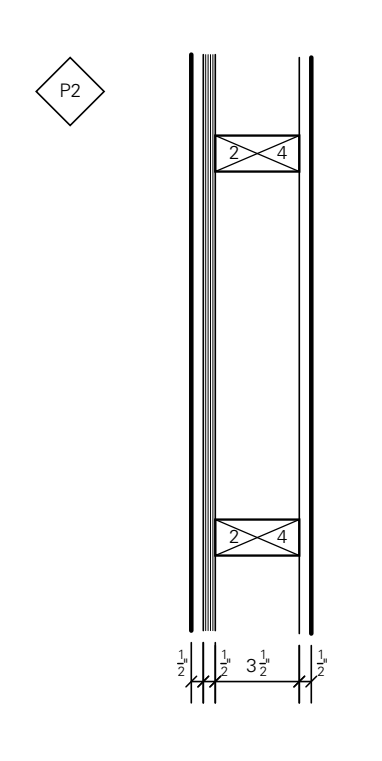

- P2 - TYP. INTERNAL SHEAR WALL**
- 1/2" PAINTED GYPSUM WALL BOARD TAPED & SANDED
 - 1/2" PLYWOOD W/ FASTENERS AS PER STRUCTURAL
 - REFER TO PLAN NOTES FOR PLYWOOD SIDE LOCATION
 - 2x4 STUDS @ 16" O.C. AS PER STRUCT.
 - 1/2" PAINTED GYPSUM WALL BOARD TAPED & SANDED

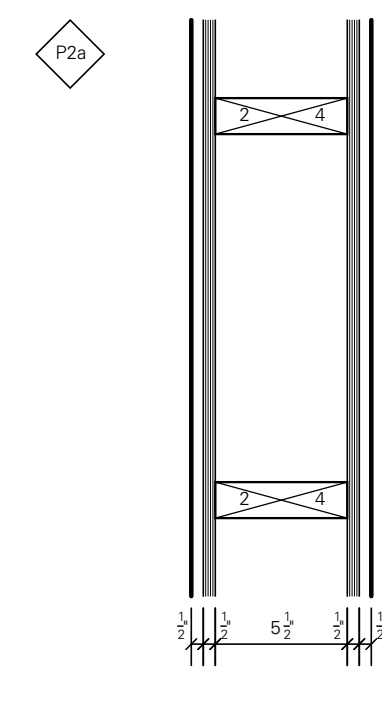

- P2a - TYP. INTERNAL SHEAR WALL**
- 1/2" PAINTED GYPSUM WALL BOARD TAPED & SANDED
 - 1/2" PLYWOOD W/ FASTENERS AS PER STRUCTURAL
 - 2x4 STUDS @ 16" O.C. AS PER STRUCT.
 - 1/2" PLYWOOD W/ FASTENERS AS PER STRUCTURAL
 - 1/2" PAINTED GYPSUM WALL BOARD TAPED & SANDED

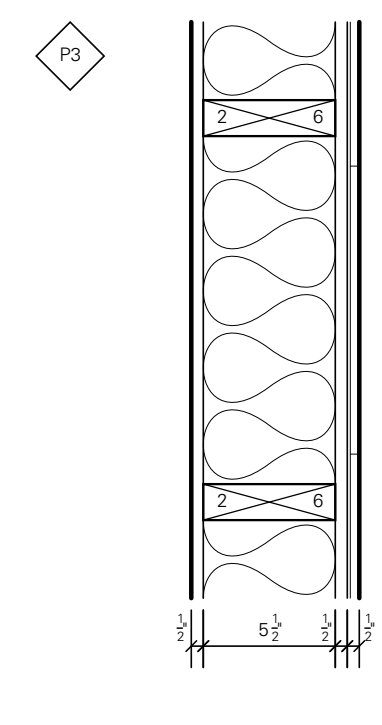

- P3 - TYP. BATHROOM PARTITION**
- 1/2" PAINTED GYPSUM WALL BOARD TAPED & SANDED
 - 2x4 STUDS @ 16" O.C. AS PER STRUCT.
 - 5 1/2" FIBERGLASS BATT INSULATION
 - 1/2" HARDIBACKER W/ RES-GUARD WATER-PROTECTED JOINTS
 - TILE AS PER INTERIOR DESIGN DWG.

ISSUES:

A	DESIGN DEVELOPMENT	28-NOV-11
B	PRICING	02-DEC-11
C	PRICING	25-APR-12
D	BUILDING PERMIT	01-AUG-12
E	ALTERATION PERMIT REVISIONS	01-NOV-12

D'ARCY JONES DESIGN INC

204 - 175 Broadway East
Vancouver BC V5T 1W2

T 604 669 2235
F 604 669 2231
E mail@darcyjones.com

SCALE:
1 1/2" = 1'-0"

DATE:
25-APR-12

DRAWN:
MP

CHECKED:
DJ

REVISION:
-

ISSUE:
PRICING

CONSULTANT:
-

Copyright reserved. All parts of this drawing are the exclusive property of D'ARCY JONES DESIGN INC and shall not be used without permission, in part or in whole.

DO NOT SCALE THESE DRAWINGS

All dimensions to be verified by contractor, trades or suppliers. Any discrepancies shall be brought to the attention of the Designer.

Any errors or omissions on this drawing shall be reported to D'ARCY JONES DESIGN INC for clarification and revision.

THE OLD HIGHWAY RENOVATION
4797 HIGHWAY
WEST VANCOUVER BC

A8.1

WALL & PARTITION ASSEMBLY SCHEDULE

1 FLOOR ASSEMBLY SCHEDULE

SCALE: 1 1/2" = 1'-0"

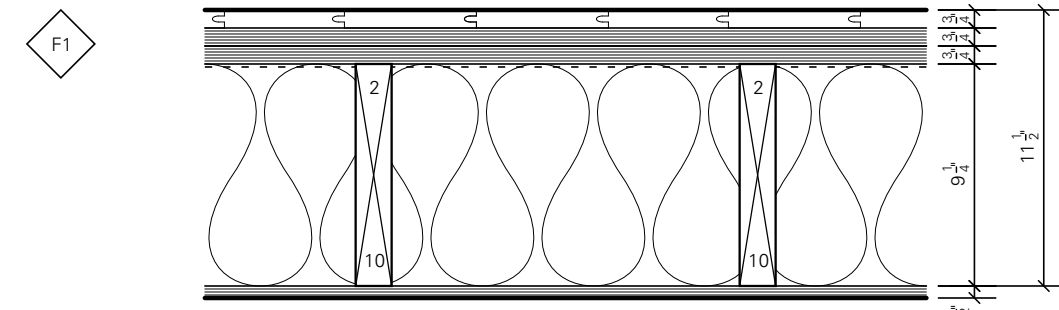

- F1 - TYP. MAIN FLOOR ASSEMBLY W/ CRAWLSPACE BELOW**
- NEW 3/4" HARDWOOD FLOORING TBD
 - NEW 3/4" PLYWOOD SHEATHING TBD
 - EXISTING 3/4" SHIPLAP TBD
 - EXISTING 6 MIL POLY TAPED & SEALED VR / AB TBD
 - EXISTING 2X10 @ 16" O.C.
 - NEW FIBERGLASS BATT INSULATION
 - NEW 1/2" PLYWOOD

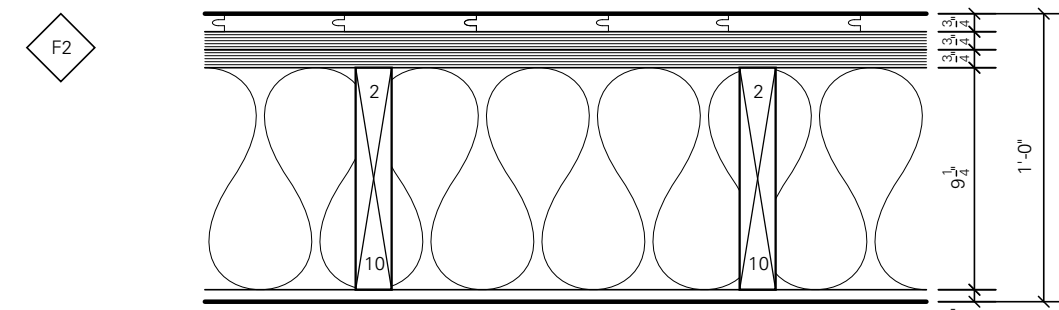

- F2 - TYP. MAIN FLOOR ASSEMBLY W/ INTERIOR SPACE BELOW**
- NEW 3/4" HARDWOOD FLOORING
 - NEW 3/4" PLYWOOD SHEATHING
 - EXISTING 3/4" SHIPLAP TBD
 - EXISTING 2X10 @ 16" O.C.
 - NEW FIBERGLASS BATT INSULATION
 - NEW 1/2" PAINTED GYPSUM WALL BOARD TAPED & SANDED

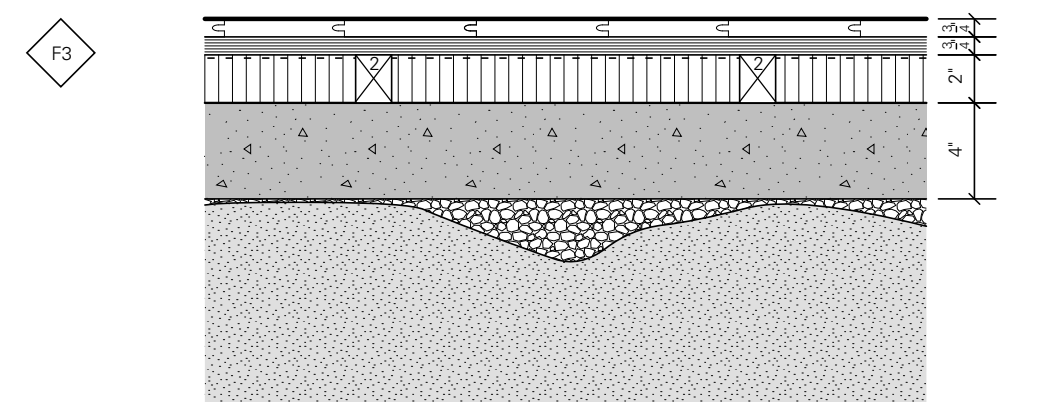

- F3 - EXISTING CONCRETE SLAB ON GRADE W/ NEW WOOD FLOORING**
- NEW 3/4" HARDWOOD FLOORING TBD
 - NEW 3/4" PLYWOOD SHEATHING
 - NEW 2x STRAPPING
 - NEW 6 MIL POLY TAPED & SEALED VR / AB TBD
 - NEW 2" RIGID INSULATION
 - EXISTING 4" CONCRETE S.O.G.
 - EXISTING COMPACTED GRAVEL FILL
 - EXISTING ROCK / SOIL

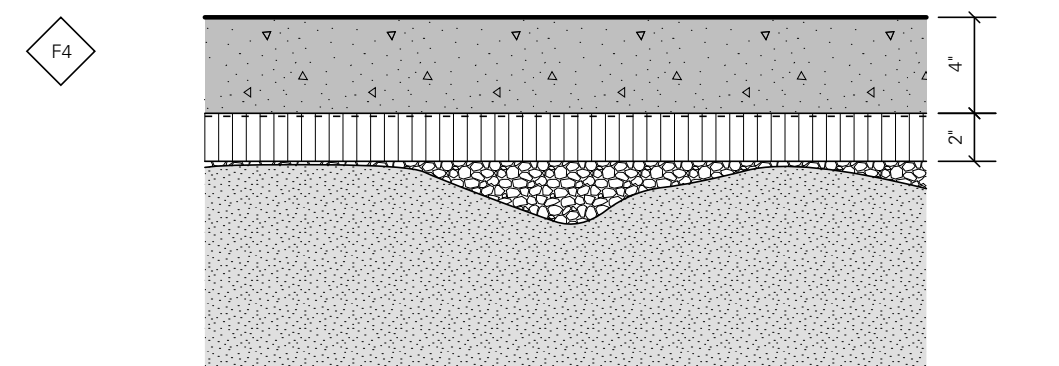

- F4 - NEW CONCRETE SLAB @ OFFICE / LAUNDRY**
- 4" POWER-REINFORCED CONCRETE S.O.G. TBD
 - 6 MIL POLY TAPED & SEALED VR / AB
 - 2" RIGID POLYSTYRENE INSULATION / MIN. R10
 - COMPACTED GRAVEL FILL AS PER STRUCT.
 - EXISTING ROCK / SOIL

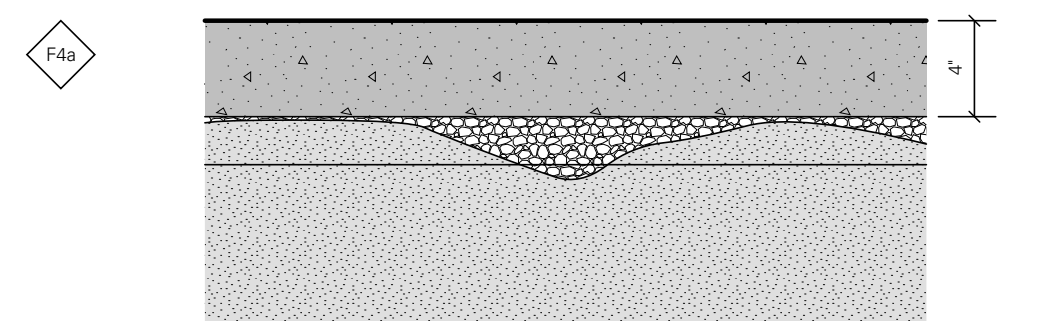

- F4a - NEW EXTERIOR SLAB-ON-GRADE**
- CLEAR SEALER
 - 4" SLAB-ON-GRADE AS PER STRUCTURAL
 - COMPACTED GRAVEL FILL AS PER STRUCT.
 - EXISTING ROCK / SOIL

2 ROOF ASSEMBLY SCHEDULE

SCALE: 1 1/2" = 1'-0"

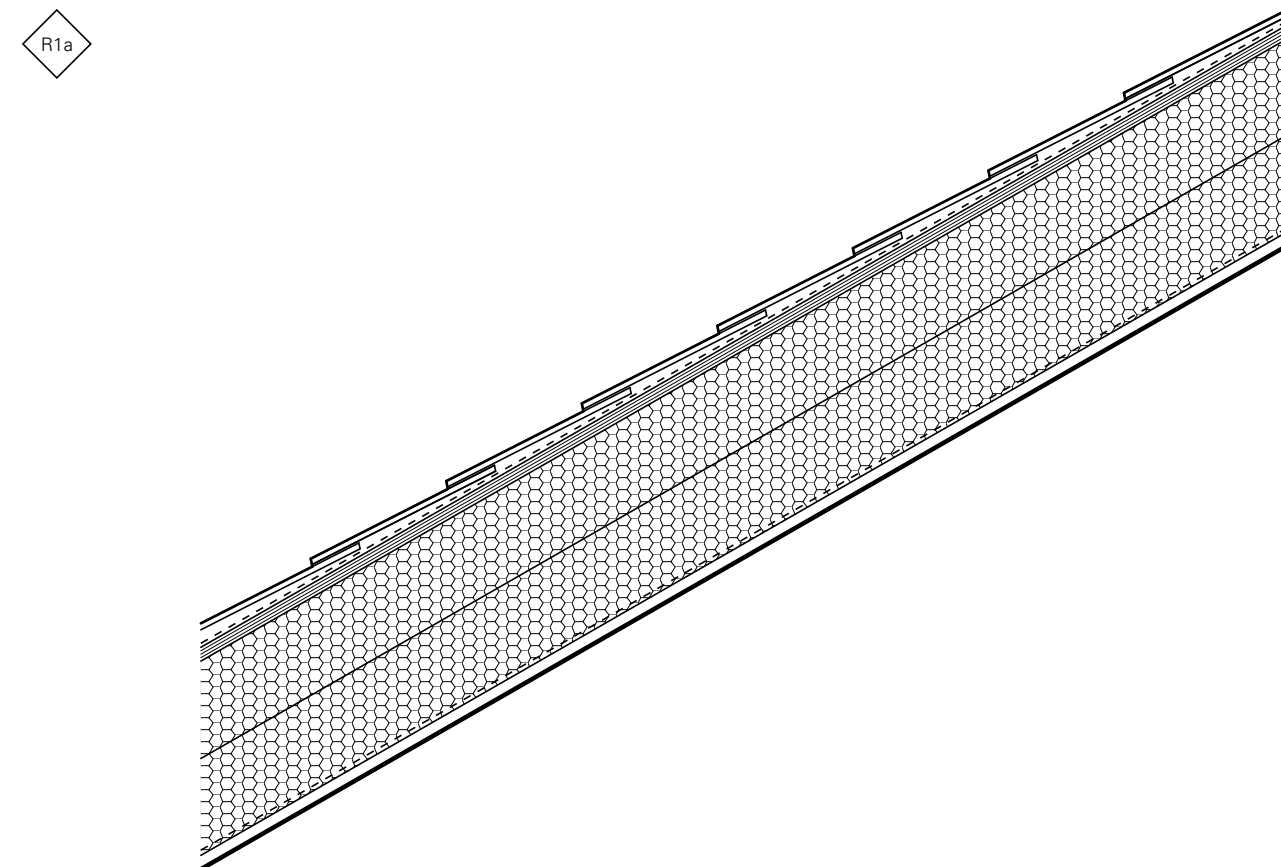

- R1a - EXISTING SLOPED ROOF W/ EXISTING VAULTED CEILING**
- NEW 30 YEAR FIBERGLASS SHINGLES
 - NEW BUILDING PAPER
 - EXISTING 1/2" PLYWOOD TBD
 - EXISTING 2X4 SLOPED RAFTERS @ 12" O.C.
 - NEW FURRING AS PER STRUCT. T.B.D.
 - NEW ICYNENE LD-C-50 SPRAY INSULATION / MIN R-28
 - NEW 6 MIL POLY TAPED & SEALED VR / AB
 - NEW 1/2" PAINTED GYPSUM WALL BOARD TAPED & SANDED

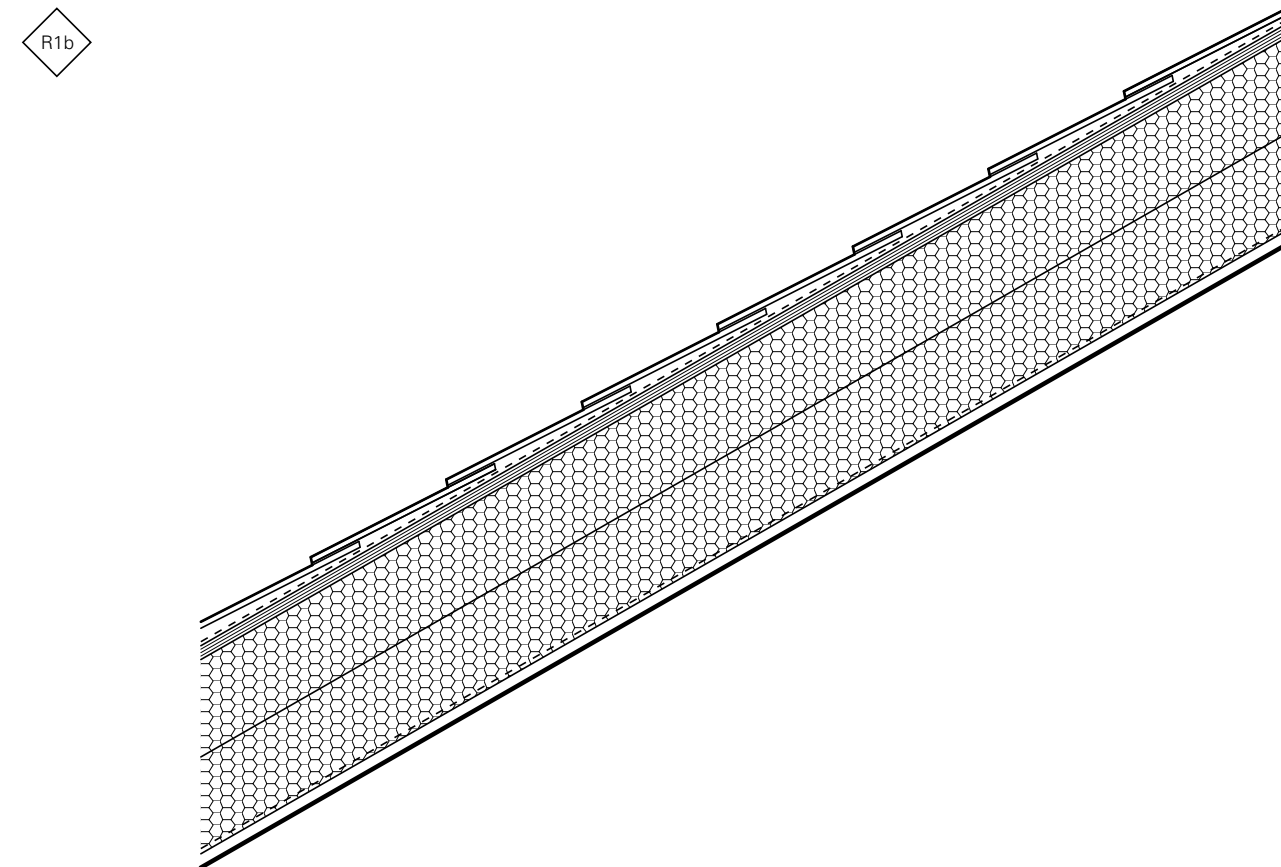

- R1b - EXISTING SLOPED ROOF W/ NEW VAULTED CEILING**
- NEW 30 YEAR FIBERGLASS SHINGLES
 - NEW BUILDING PAPER
 - EXISTING 1/2" PLYWOOD TBD
 - EXISTING 2X4 SLOPED RAFTERS @ 12" O.C.
 - NEW FURRING AS PER STRUCT. T.B.D.
 - NEW ICYNENE LD-C-50 SPRAY INSULATION / MIN R-28
 - NEW 6 MIL POLY TAPED & SEALED VR / AB
 - NEW 1/2" PAINTED GYPSUM WALL BOARD TAPED & SANDED

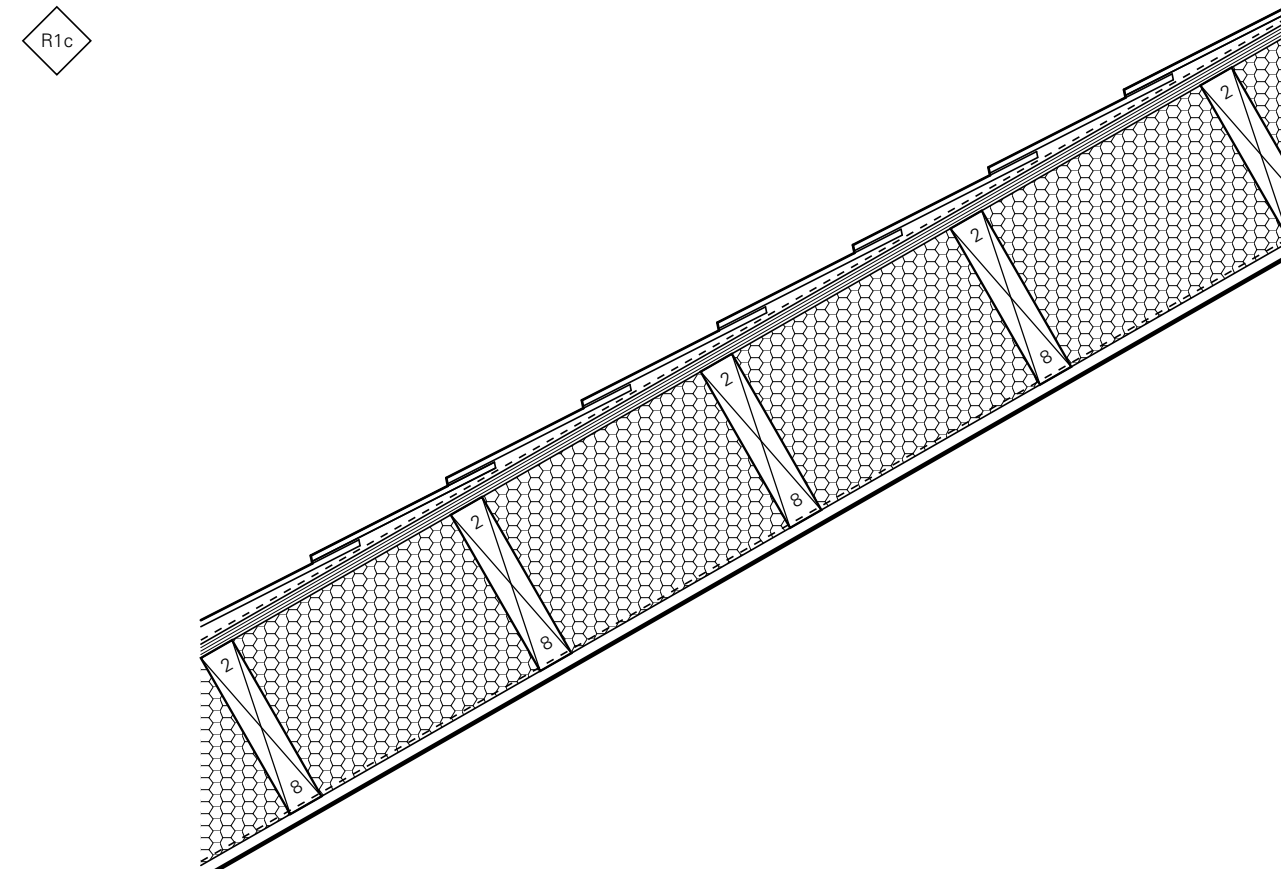

- R1c - NEW SLOPED ROOF W/ NEW VAULTED CEILING**
- NEW 30 YEAR FIBERGLASS SHINGLES
 - NEW BUILDING PAPER
 - NEW 1/2" PLYWOOD TBD
 - NEW 2X8 SLOPED RAFTERS @ 12" O.C.
 - NEW ICYNENE LD-C-50 SPRAY INSULATION / MIN R-28
 - NEW 6 MIL POLY TAPED & SEALED VR / AB
 - NEW 1/2" PAINTED GYPSUM WALL BOARD TAPED & SANDED

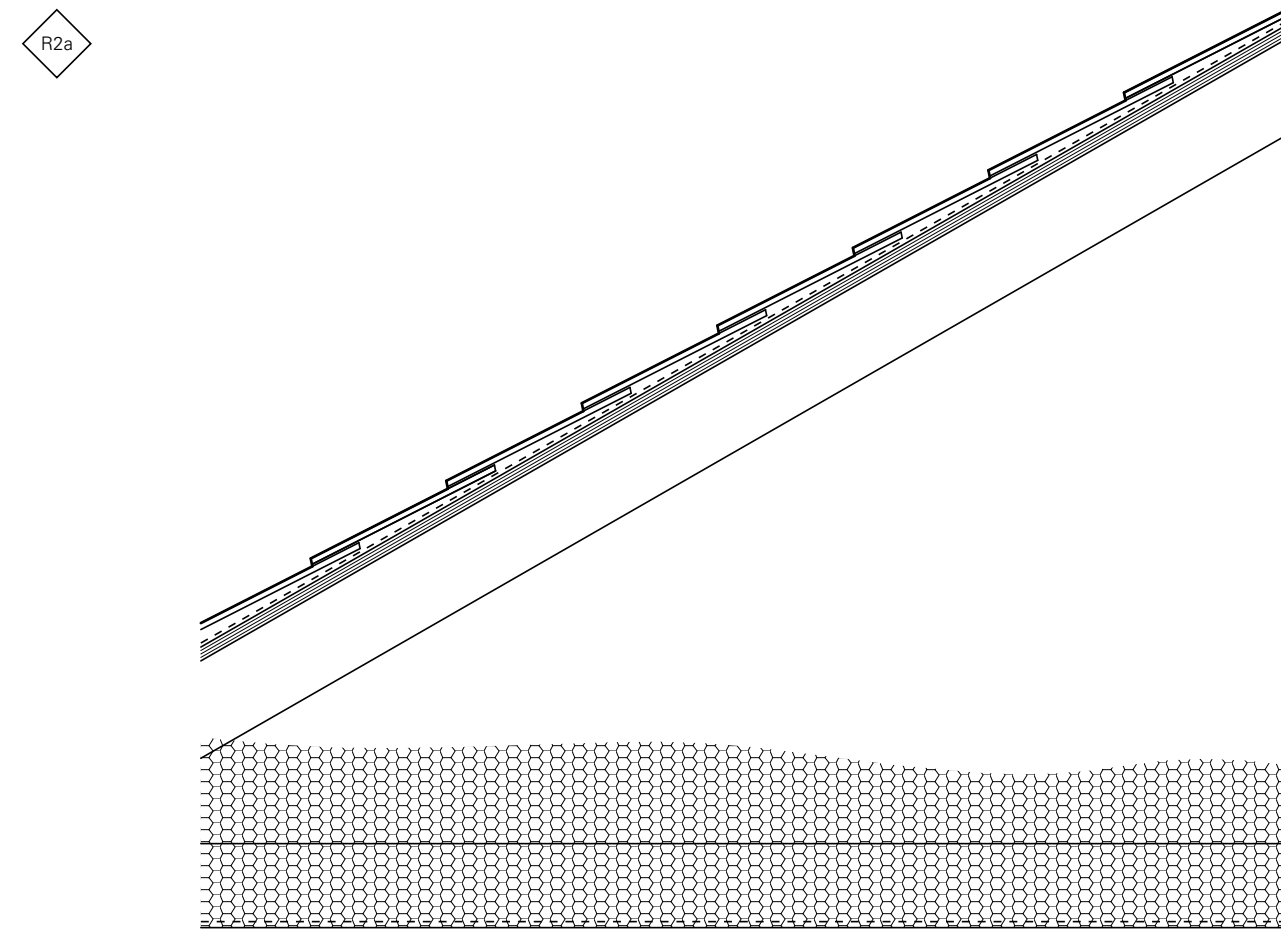

- R2a - EXISTING SLOPED ROOF W/ EXISTING DROPPED CEILING**
- NEW 30 YEAR FIBERGLASS SHINGLES
 - NEW BUILDING PAPER
 - EXISTING 1/2" PLYWOOD TBD
 - EXISTING 2X4 SLOPED RAFTERS @ 12" O.C.
 - NEW ICYNENE LD-C-50 SPRAY INSULATION / MIN R-28
 - EXISTING 2X4 CEILING RAFTERS @ 16" O.C.
 - NEW 6 MIL POLY TAPED & SEALED VR / AB
 - NEW 1/2" PAINTED GYPSUM WALL BOARD TAPED & SANDED

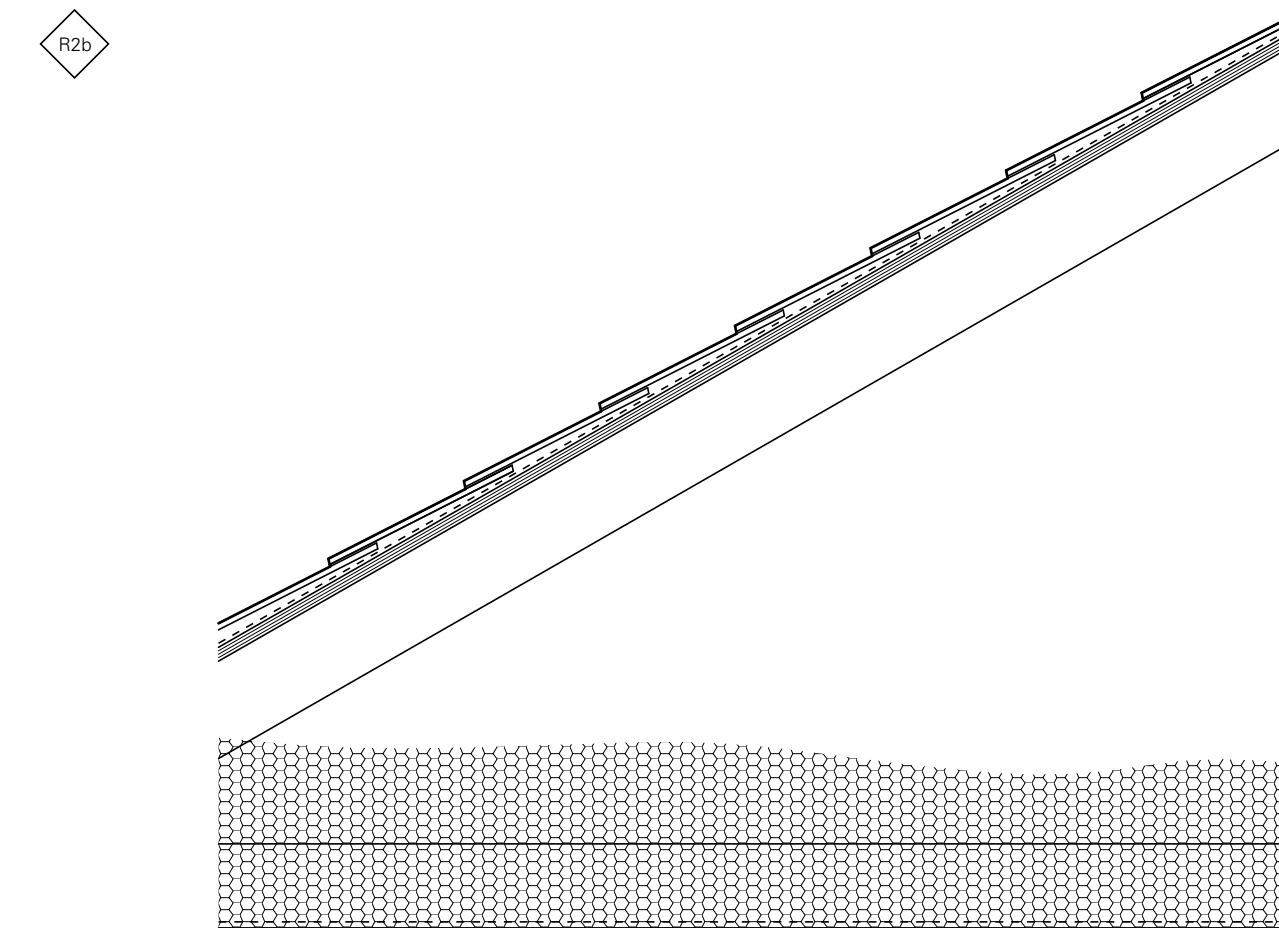

- R2b - EXISTING SLOPED ROOF W/ NEW DROPPED CEILING**
- NEW 30 YEAR FIBERGLASS SHINGLES
 - NEW BUILDING PAPER
 - EXISTING 1/2" PLYWOOD TBD
 - EXISTING 2X4 SLOPED RAFTERS @ 12" O.C.
 - NEW ICYNENE LD-C-50 SPRAY INSULATION / MIN R-28
 - NEW 2X4 CEILING RAFTERS @ 16" O.C.
 - NEW 6 MIL POLY TAPED & SEALED VR / AB
 - NEW 1/2" PAINTED GYPSUM WALL BOARD TAPED & SANDED

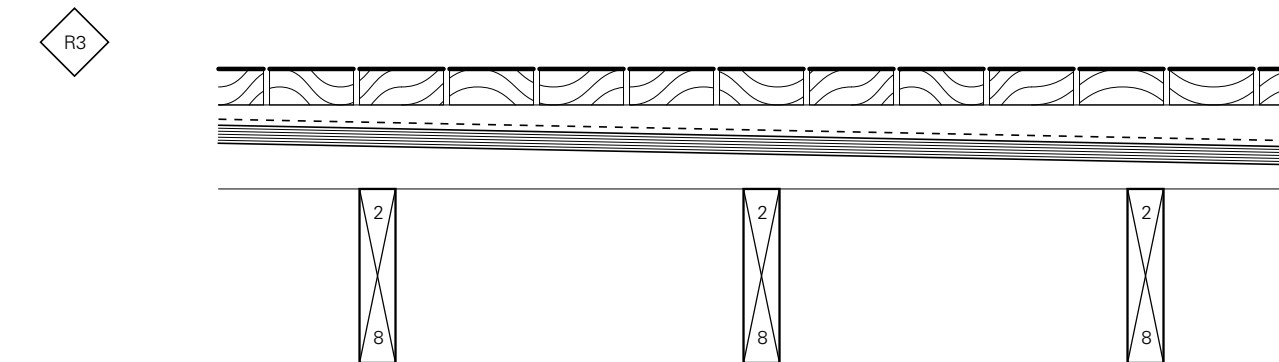

- R3 - DECK ASSEMBLY**
- 2x4 IPE WOOD DECKING W/ 1/4" GAPS
 - PP GANT STRIPS AS REQ'D
 - 2-PLY S.B.S. TORCH-ON MEMBRANE
 - 3/4" EXT. GRADE PLYWOOD SHEATHING
 - 2x4 STRAPPING @ 16" O.C. TAPEDED 2x TO 0" AT DRAIN
 - 2x8 @ 16" O.C. AS PER STRUCTURAL

ISSUES:

A	DESIGN DEVELOPMENT	28-NOV-11
B	PRICING	02-DEC-11
C	PRICING	25-APR-12
D	BUILDING PERMIT	01-AUG-12
E	ALTERATION PERMIT REVISIONS	01-NOV-12

D'ARCY JONES DESIGN INC
 204 - 175 Broadway East
 Vancouver BC V5T 1W2
 T 604 669 2235
 F 604 669 2231
 E mail@darcyjones.com

SCALE:
1 1/2" = 1'-0"
 DATE:
25-APR-12
 DRAWN:
MP
 CHECKED:
DJ
 REVISION:
-
 ISSUE:
PRICING
 CONSULTANT:
-

Copyright reserved. All parts of this drawing are the exclusive property of D'ARCY JONES DESIGN INC and shall not be used without permission, in part or in whole.
 DO NOT SCALE THESE DRAWINGS
 All dimensions to be verified by contractor, trades or suppliers. Any discrepancies shall be brought to the attention of the Designer.
 Any errors or omissions on this drawing shall be reported to D'ARCY JONES DESIGN INC for clarification and revision.

THE OLD HIGHWAY RENOVATION
 4797 HIGHWAY
 WEST VANCOUVER BC

A8.2

FLOOR & ROOF ASSEMBLY SCHEDULE